

YAMAHA

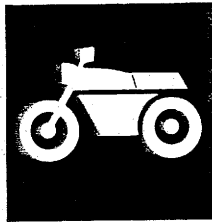

**PARTS
CATALOGUE**

YZ80E (4ES1)

U.S.A., CANADA, NEW ZEALAND, S. AFRICA

234ES-100E1

YAMAHA
GENUINE
Parts & Accessories

A2



A3

FOREWORD

This Parts Catalogue is related to the parts in use for the Yamaha YZ80E(4ES1). When you are ordering replacement parts for the YZ80E(4ES1), refer to this Parts Catalogue and quote both part numbers and part names correctly.

1. Modifications or additions which have been made after issue of the Parts Catalogue will be announced in the Yamaha Parts News.

It is advisable that according to the Yamaha Parts News you make necessary corrections to the Parts Catalogue on hand to keep it up-to-date.

2. Abbreviations

The following abbreviations are used in this Parts Catalogue.

U.R. Use size (thickness) and/or number as required.

U.N. Use as many as you need.

A.P. Alternate Parts

L.M. Local Made

F# Frame No. (Applicable machine No.)

3. The parts marked with (*) in the parts number column of this Catalogue are not supplied with by Yamaha, those have to be found locally.

4. Parts, which are to be supplied in the form of assemblies, are listed with an indention of one letter's space, and a dot (.) is put against the name of each part.

EXAMPLE CARBURETOR ASS'Y
 . JET, pilot
 . NOZZLE, main

5. Indication of No. of constituent parts for assembly

The numeral appearing to the right of each constituent part under the description indicates the quantity of such parts for each individual assembly unit.

EXAMPLE

Part No.	Description	Q'ty	Remarks
2F5-83310-60	FRONT FLASHER LIGHT ASS'Y	2	
115-83311-60	. BULB (6V-18W)	1	
1M1-83309-60	. REFLECTOR	1	

6. Initial Serial No. and Color Code

(A) Frame Serial No.	4ES-000101 and following
(B) Engine Serial No.	4ES-000101 and following

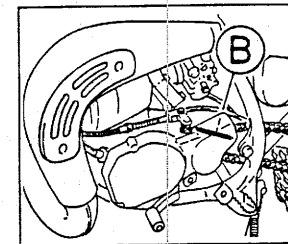
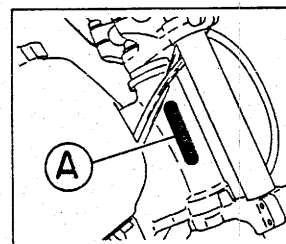

Color Code	Color Name	Abbreviate
0206	PURPLISH WHITE SOLID 1	PWS1

7. Applicable colors of graphics are represented in the "Remarks" column by the letter(s) appropriately picked out of the full word(s) showing such colors.

EXAMPLE

Part No.	Description	Q'ty	Remarks
2N4-24110-00-X5	FUEL TANK COMP.	1	MAXIM RED
3J1-24240-10	. GRAPHIC, fuel tank set	1	for MXR

CONTENTS

ENGINE

Cylinder	B2
Crankshaft. Piston	B3
Water Pump	B4
Radiator. Hose	B5
Intake	B6
Carburetor	B7~B8
Exhaust	B9
Crankcase	B10
Crankcase Cover 1	B11
Starter	B12
Clutch	B13
Transmission	B14~B15
Shift Cam. Fork	C2
Shift Shaft	C3

CHASSIS

Frame	C4
Fender	C5
Side Cover	C6
Rear Arm	C7~C8
Rear Suspension	C9
Steering	C10
Front Fork	C11~C12
Fuel Tank	C13
Seat	C14
Front Wheel	C15
Front Brake Caliper	D2
Rear Wheel	D3
Rear Brake Caliper	D4

Steering Handle. Cable	D5
Front Master Cylinder	D6
Stand. Footrest	D7
Rear Master Cylinder	D8
Generator	D9
Handle Switch. Lever	D10
Electrical 1	D11

ALTERNATE PARTS

Alternate (Chassis)	D12
---------------------------	-----

REPAIR KIT

Repair Kit	D13
------------------	-----

INDEX

Numerical Index	M1~M3
-----------------------	-------

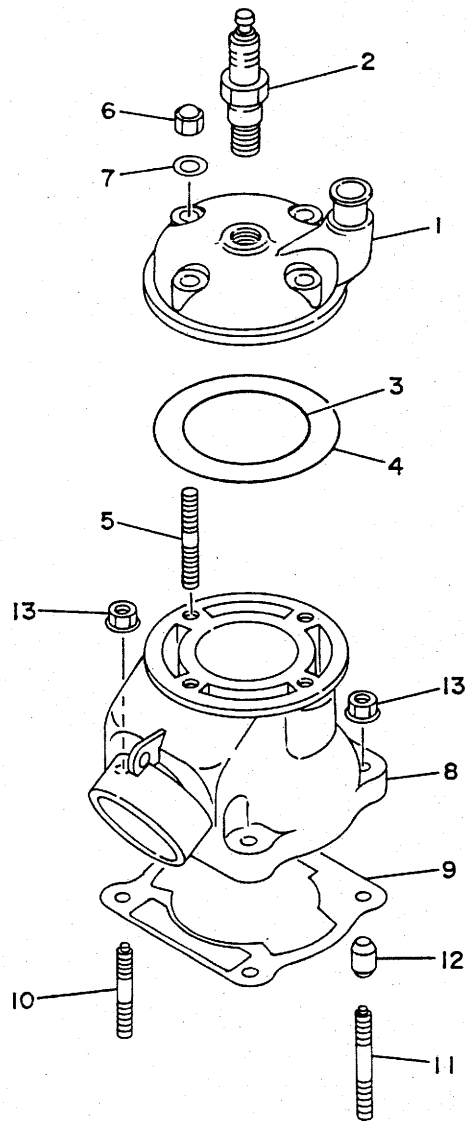

FIG. 1 CYLINDER

REF. NO.	PART NO.	DESCRIPTION	Q'TY	REMARKS
1	4ES-11111-00	HEAD, CYLINDER 1	1	
2	94702-00367	PLUG, SPARK (NGK B10EG)	1	UR
	94702-00368	PLUG, SPARK (NGK BR10EG)	1	UR FOR CANADA,S.AFRICA
3	93210-56459	O-RING	1	
4	93210-84724	O-RING	1	
5	90116-08394	BOLT, STUD	4	
6	90176-08026	NUT, CROWN	4	
7	90201-08087	WASHER, PLATE	4	
8	4ES-11311-00	CYLINDER 1	1	
9	4ES-11351-00	GASKET, CYLINDER	1	
10	90116-08318	BOLT, STUD	2	
11	90116-08388	BOLT, STUD	2	
12	99510-10114	PIN, DOWEL	2	
13	90179-08491	NUT	4	



4ES1100-3010

FIG. 2 CRANKSHAFT. PISTON

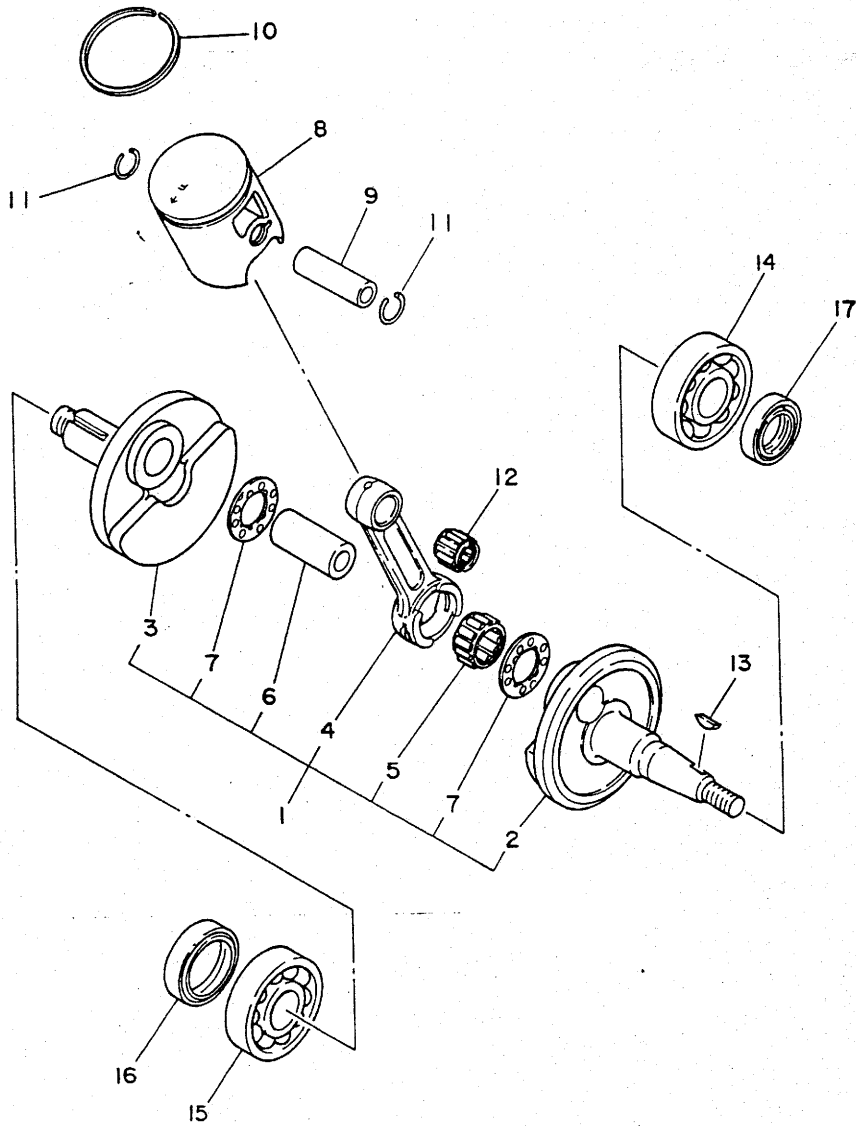

REF. NO.	PART NO.	DESCRIPTION	Q'TY	REMARKS
1	4ES-11400-00	CRANKSHAFT ASSY	1	
2	4ES-11412-00	.CRANK 1	1	
3	4ES-11422-00	.CRANK 2	1	
4	4ES-11651-00	.ROD, CONNECTING	1	
5	93310-420D8	.BEARING, CYLINDRICAL	1	
6	2RA-11681-00	.PIN, CRANK 1	1	
7	90209-20159	.WASHER	2	
8	4ES-11631-00-A0	PISTON (STD)	1	UR RED
	4ES-11631-00-B0	PISTON (STD)	1	UR ORANGE
	4ES-11631-00-C0	PISTON (STD)	1	UR GREEN
	4ES-11631-00-D0	PISTON (STD)	1	UR PURPLE
9	4ES-11633-00	PIN, PISTON	1	
10	43K-11611-00	RING, PISTON	1	
11	93450-16115	CIRCLIP	2	
12	93310-214F8	BEARING, CYLINDRICAL	1	KOYO
13	90280-03017	KEY, WOODRUFF	1	
14	93306-20468	BEARING	1	
15	93306-30421	BEARING (B6304C3)	1	
16	93103-28126	OIL SEAL	1	
17	93102-20447	OIL SEAL	1	

4ES1100-3020



B3

FIG. 3 WATER PUMP

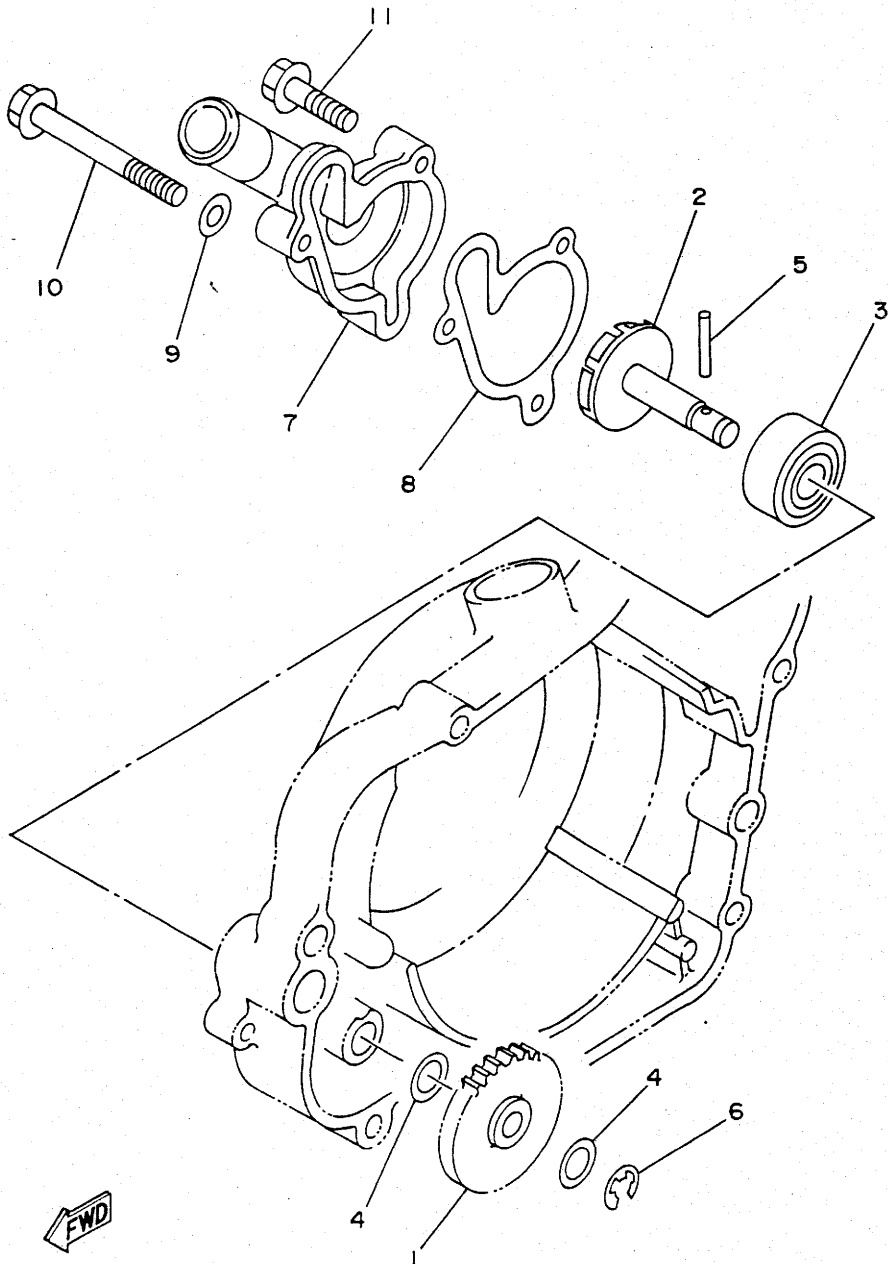

REF. NO.	PART NO.	DESCRIPTION	Q'TY	REMARKS
1	4ES-12459-00	GEAR, IMPELLER SHAFT	1	
2	36F-12450-00	IMPELLER SHAFT ASSY	1	
3	93103-10168	OIL SEAL	1	
4	90201-08512	WASHER, PLATE	2	
5	93603-22028	PIN, DOWEL	1	
6	99080-07600	CIRCLIP	1	
7	4BA-12422-00	COVER, HOUSING	1	
8	4BA-12428-00	GASKET, HOUSING COVER 2	1	
9	90430-06166	GASKET	1	
10	95821-06060	BOLT, FLANGE	1	
11	95023-06025	BOLT	2	



4ES1100-3030

B4

FIG. 4 RADIATOR. HOSE

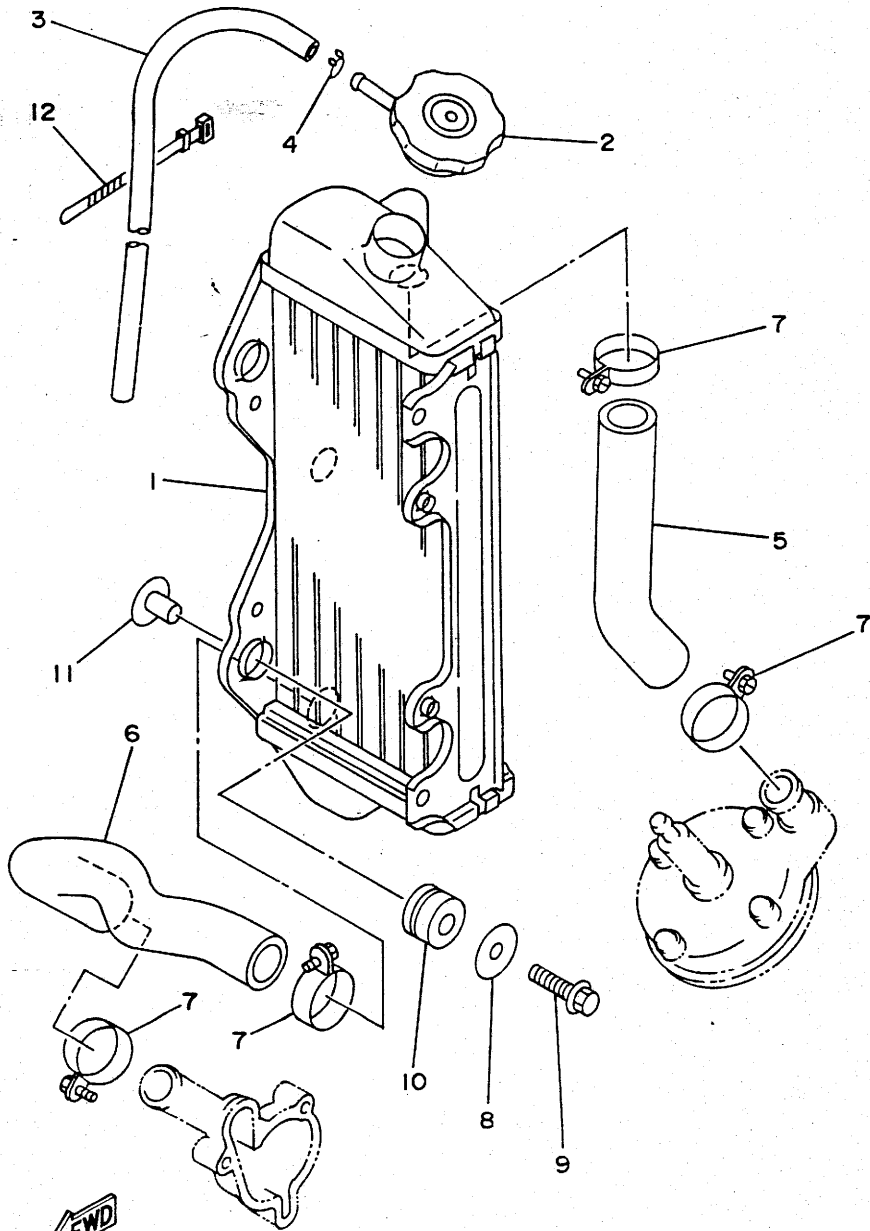

REF. NO.	PART NO.	DESCRIPTION	Q'TY	REMARKS
1	4ES-12461-00	RADIATOR ASSY	1	
2	22W-12462-00	CAP, RADIATOR	1	
3	22W-12463-00	PIPE, BREATHER	1	
4	90467-08004	CLIP	1	
5	4ES-12481-00	PIPE 1	1	
6	4ES-12482-00	PIPE 2	1	
7	90450-28014	HOSE CLAMP ASSY	4	
8	90201-06067	WASHER, PLATE	3	
9	95023-06030	BOLT	3	
10	90480-15528	GROMMET	3	
11	90387-0700G	COLLAR	3	
12	437-83936-01	BAND, SWITCH CORD	1	

4ES1100-3040

B5

FIG. 5 INTAKE

REF. NO.	PART NO.	DESCRIPTION	Q'TY	REMARKS
1	4ES-13610-00	REED VALVE ASSY	1	
2	4ES-13613-00	.REED, VALVE	2	
3	4ES-13616-00	.STOPPER, REED VALVE	2	
4	98580-03008	.SCREW, PAN HEAD	4	
5	92990-03100	.WASHER, SPRING	4	
6	4ES-13565-00	JOINT, CARBURETOR	1	
7	95023-06020	BOLT	4	
8	90460-43053	CLAMP, HOSE	1	
9	90460-51059	CLAMP, HOSE	1	
10	4ES-14453-00	JOINT, AIR CLEANER 1	1	
11	4ES-14459-00	HOLDER, GUIDE	1	
12	4ES-14462-00	.SEAL	1	
13	90167-05031	SCREW, TAPPING	5	
14	90450-99064	HOSE CLAMP ASSY	1	
15	4ES-14411-00	CASE, AIR CLEANER 1	1	
16	4ES-14451-00	ELEMENT, AIR CLEANER	1	
17	4ES-14458-00	GUIDE	1	
18	90209-06096	WASHER	1	
19	90122-06034	BOLT, WING	1	
20	92995-06100	WASHER	1	

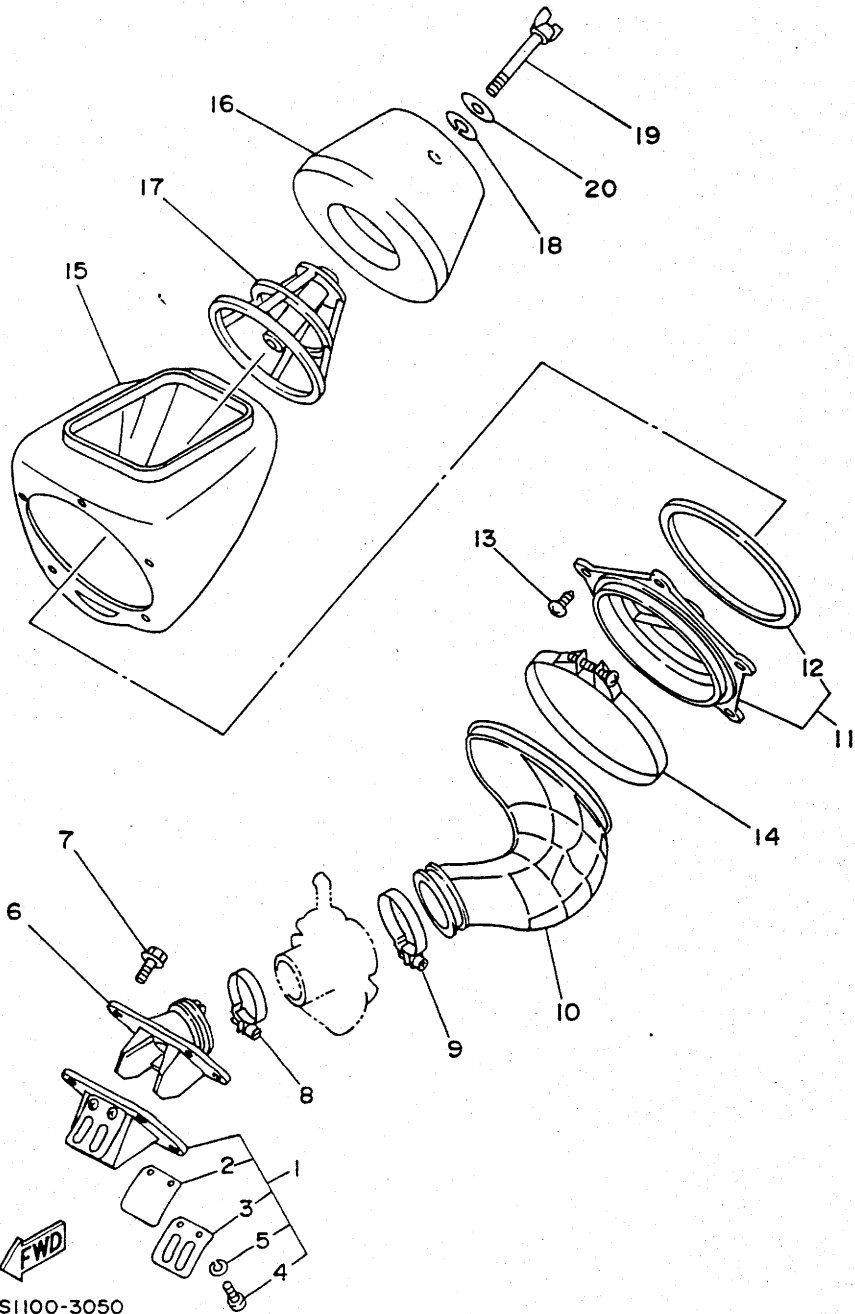

4ES1100-3050

B6

FIG. 6 CARBURETOR

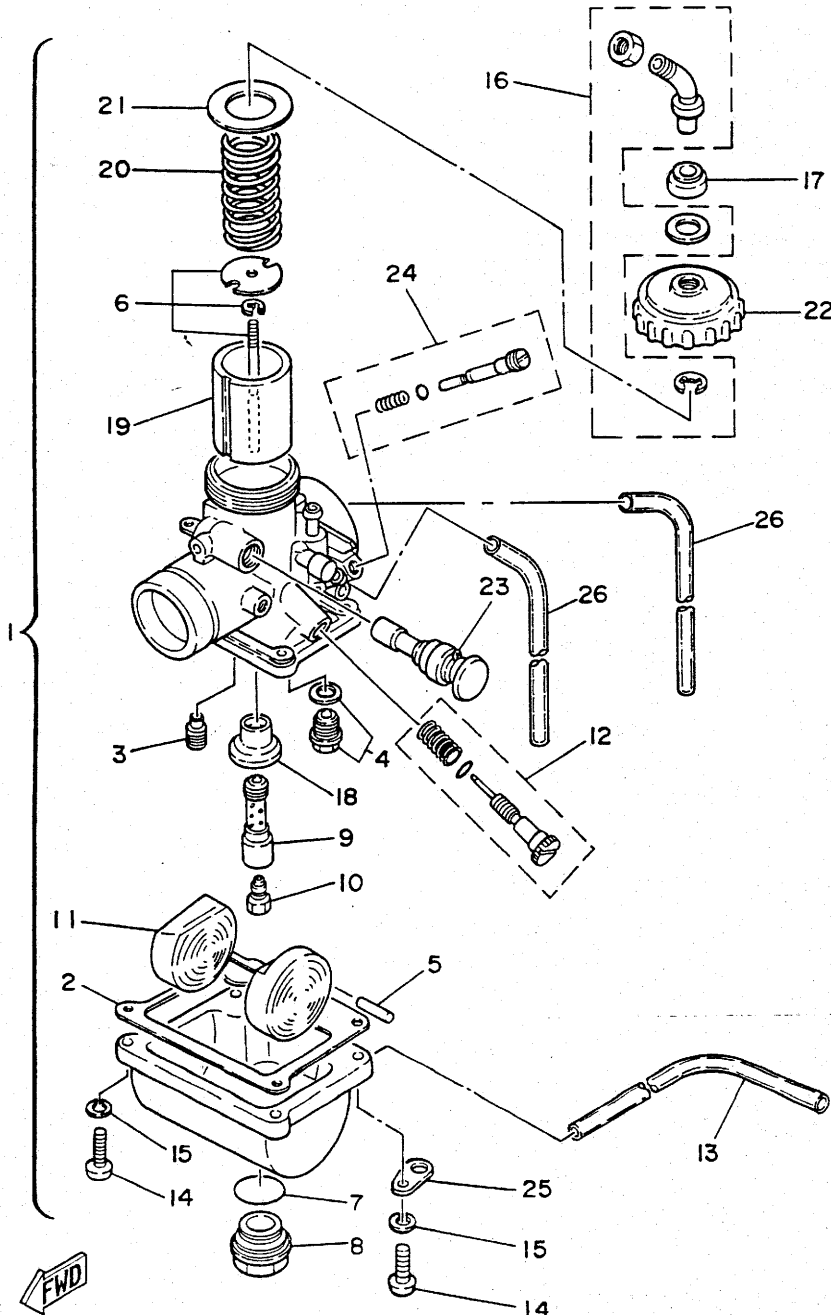

REF. NO.	PART NO.	DESCRIPTION	Q'TY	REMARKS
1	4ES-14101-00	CARBURETOR ASSY 1	1	
2	304-14184-00	.GASKET, FLOAT CHAMBER	1	
3	260-14142-35	.JET, PILOT (# 35)	1	STD
	260-14142-30	.JET, PILOT (# 30)	1	AP
	260-14142-40	.JET, PILOT (# 40)	1	AP
4	23L-14107-25	.NEEDLE VALVE SET	1	
5	127-14186-00	.PIN, FLOAT	1	
6	58T-1490J-00	.NEEDLE SET	1	
7	93210-18288	.O-RING	1	
8	3R1-14115-00	.PLUG, SCREW	1	
9	3R1-14141-52	.NOZZLE, MAIN	1	STD
	3R1-14141-50	.NOZZLE, MAIN	1	AP
	3R1-14141-54	.NOZZLE, MAIN	1	AP
10	137-14143-54-A1	.JET, MAIN (#270)	1	STD
	137-14143-52	.JET, MAIN (#260)	1	AP
	137-14143-56-A0	.JET, MAIN (#280)	1	AP
11	314-14185-00	.FLOAT	1	
12	31J-14103-00	.THROTTLE SCREW SET	1	
13	278-14197-00	.PIPE	1	
14	98511-04016	.SCREW, PAN HEAD	4	
15	92902-04100	.WASHER, SPRING	4	
16	22W-14106-00	.CABLE ADJUST SCREW SET	1	
17	3X3-14169-00	.CAP	1	
18	39K-14153-00	.WASHER, MAIN JET	1	
19	2X6-14112-30	.VALVE, THROTTLE 1	1	STD
	2X6-14112-25	.VALVE, THROTTLE 1	1	AP
	2X6-14112-35	.VALVE, THROTTLE 1	1	AP
20	248-14131-00	.SPRING, THROTTLE VALVE	1	

4ES1100-3060

B7

FIG. 6 CARBURETOR

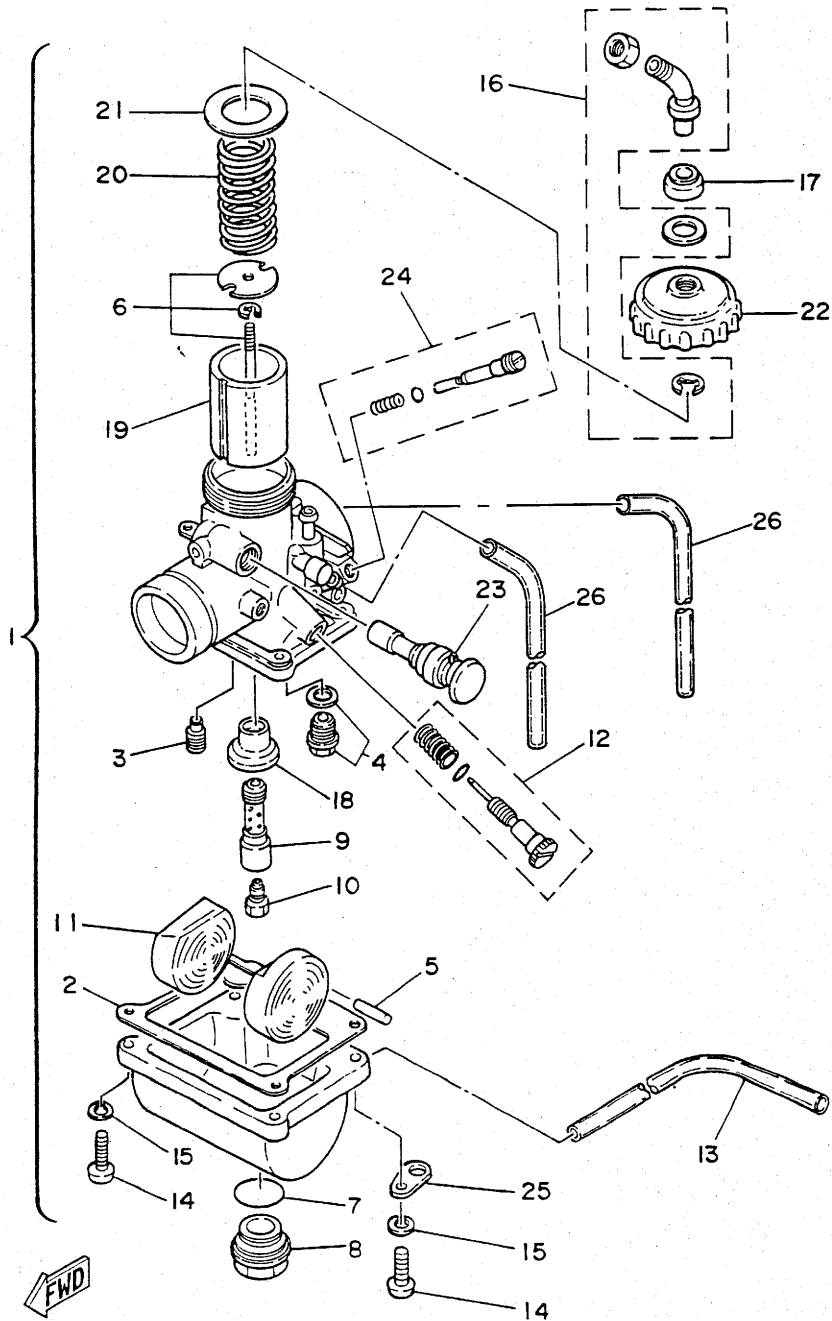

REF. NO.	PART NO.	DESCRIPTION	Q'TY	REMARKS
21	2A6-14126-00	.GASKET	1	
22	2A6-14158-00	.TOP, MIXING CHAMBER	1	
23	4U5-14171-00	.PLUNGER, STARTER	1	
24	10W-14104-00	.AIR SCREW SET	1	
25	132-14146-00	.PLATE	1	
26	55X-14196-00	.PIPE	2	

4ES1100-3060

B8

FIG. 7 EXHAUST

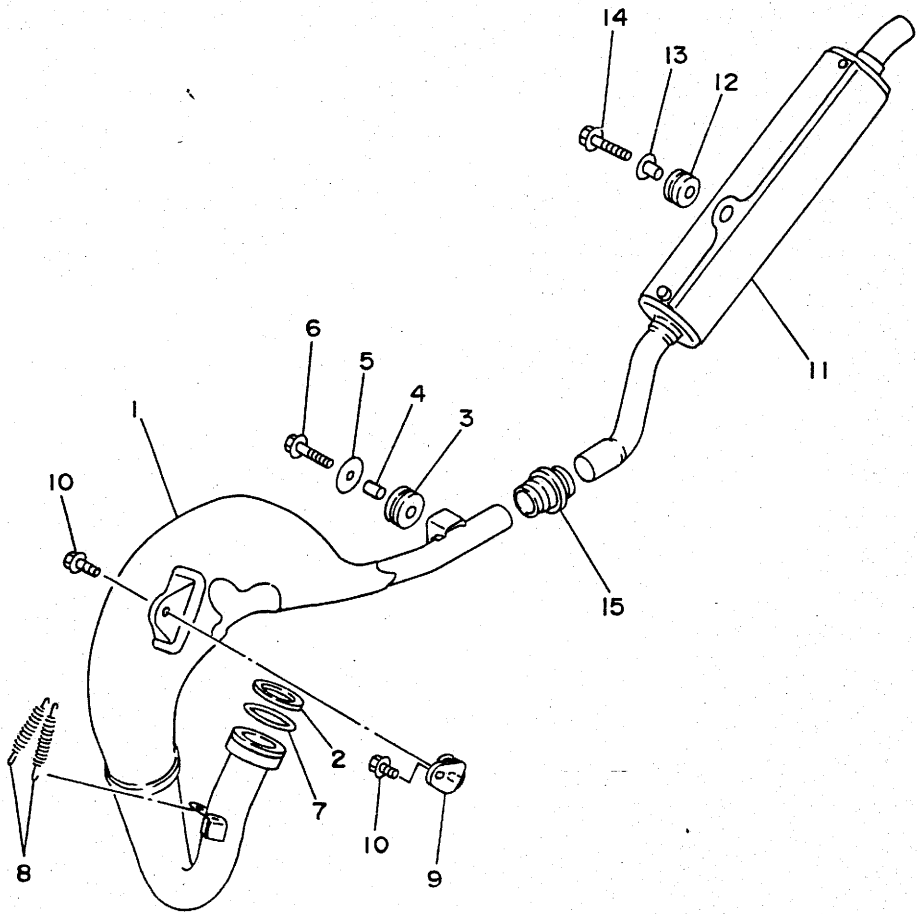

REF. NO.	PART NO.	DESCRIPTION	Q'TY	REMARKS
1	4ES-14610-00	EXHAUST PIPE ASSY 1	1	
2	90201-33299	WASHER, PLATE	1	
3	90480-18411	GROMMET	1	
4	90387-105L0	COLLAR	1	
5	90201-060A3	WASHER, PLATE	1	
6	95023-06025	BOLT	1	
7	93210-371A9	O-RING	1	
8	90507-20030	SPRING, TENSION	2	
9	565-14771-00	STAY, MUFFLER 1	1	
10	95023-06012	BOLT	2	
11	4ES-14753-00	SILENCER, EXHAUST	1	
12	90480-16561	GROMMET	1	
13	90387-063G3	COLLAR	1	
14	95023-06025	BOLT	1	
15	17W-14615-00	JOINT, EXHAUST 1	1	



4ES1100-3070

B9

FIG. 8 CRANKCASE

REF. NO.	PART NO.	DESCRIPTION	Q'TY	REMARKS
1	4ES-15111-00	CRANKCASE 1	1	
2	4ES-15121-00	CRANKCASE 2	1	
3	99530-10014	PIN, DOWEL	2	
4	98580-06040	SCREW, PAN HEAD	3	
5	98580-06550	SCREW, PAN HEAD	5	
6	92580-06560	SCREW, PAN HEAD	3	
7	583-15371-00	BREATHER	1	
8	90446-07349	HOSE	1	

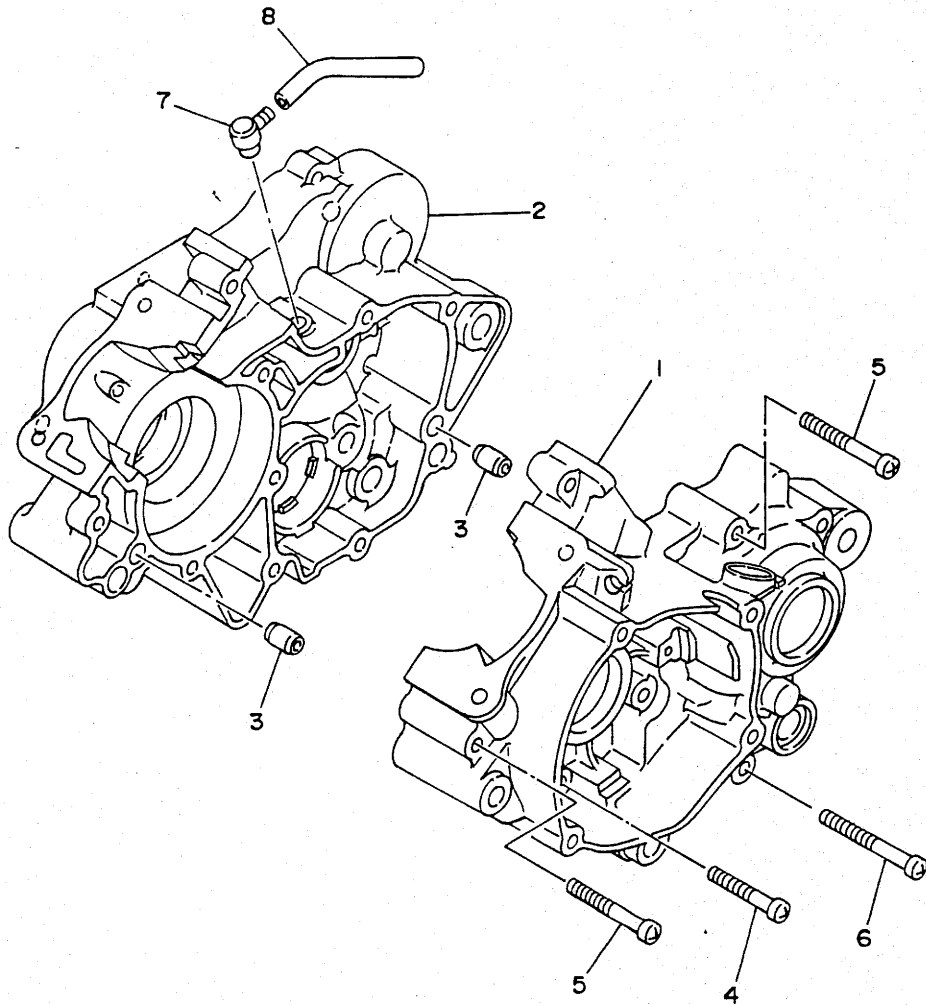

4ES1100-3080

B10

FIG. 9 CRANKCASE COVER 1

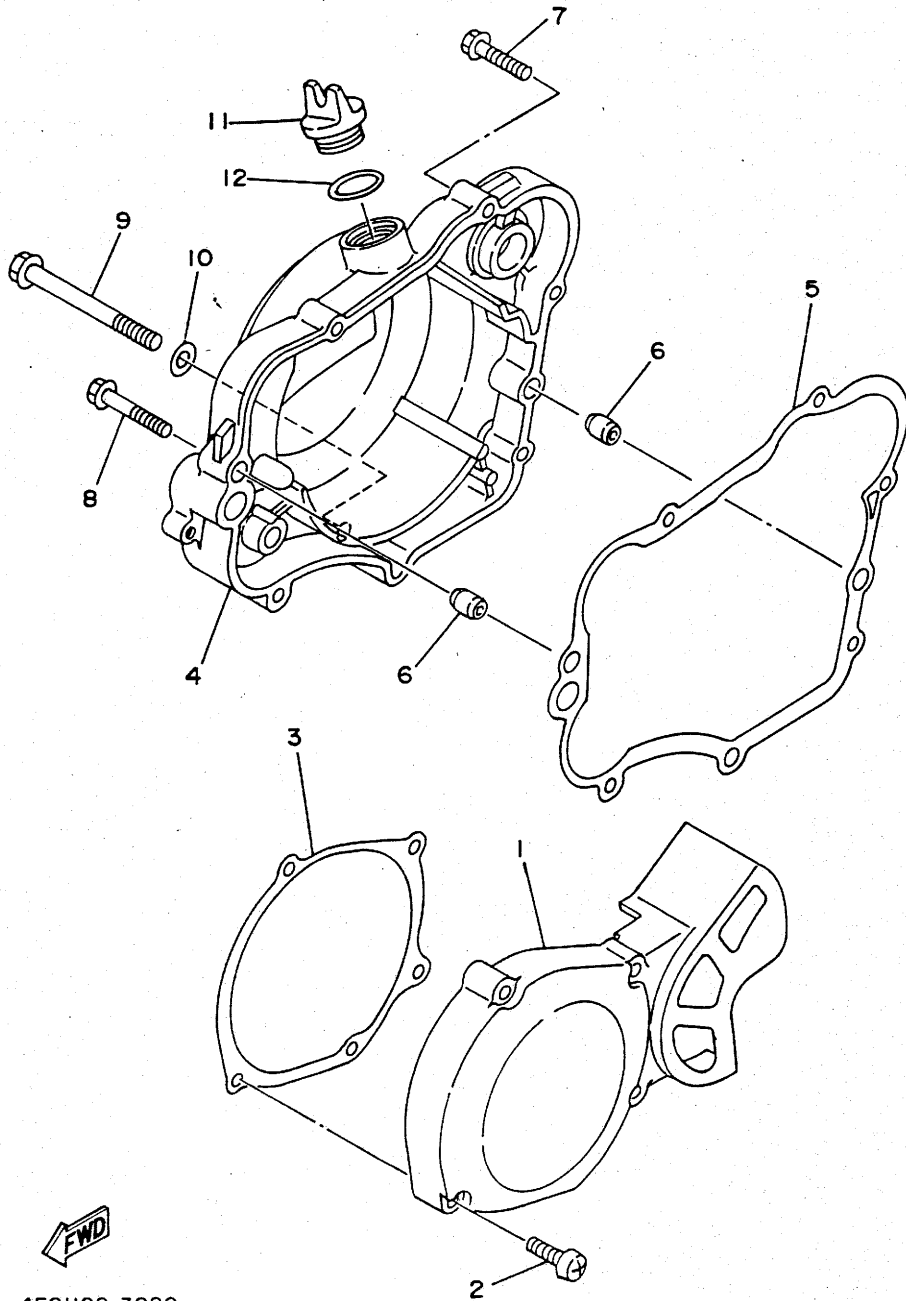

REF. NO.	PART NO.	DESCRIPTION	Q'TY	REMARKS
1	4ES-15411-00	COVER, CRANKCASE 1	1	
2	98580-06030	SCREW, PAN HEAD	4	
3	4ES-15451-00	GASKET, CRANKCASE COVER 1	1	
4	4ES-15421-00	COVER, CRANKCASE 2	1	
5	4ES-15461-00	GASKET, CRANKCASE COVER 2	1	
6	99530-10014	PIN, DOWEL	2	
7	95023-06030	BOLT	4	
8	95023-06040	BOLT	1	
9	95021-08080	BOLT, FLANGE	1	
10	90201-08087	WASHER, PLATE	1	
11	1RG-15363-00	PLUG, OIL	1	
12	93210-19123	O-RING	1	



4ES1100-3090

B11

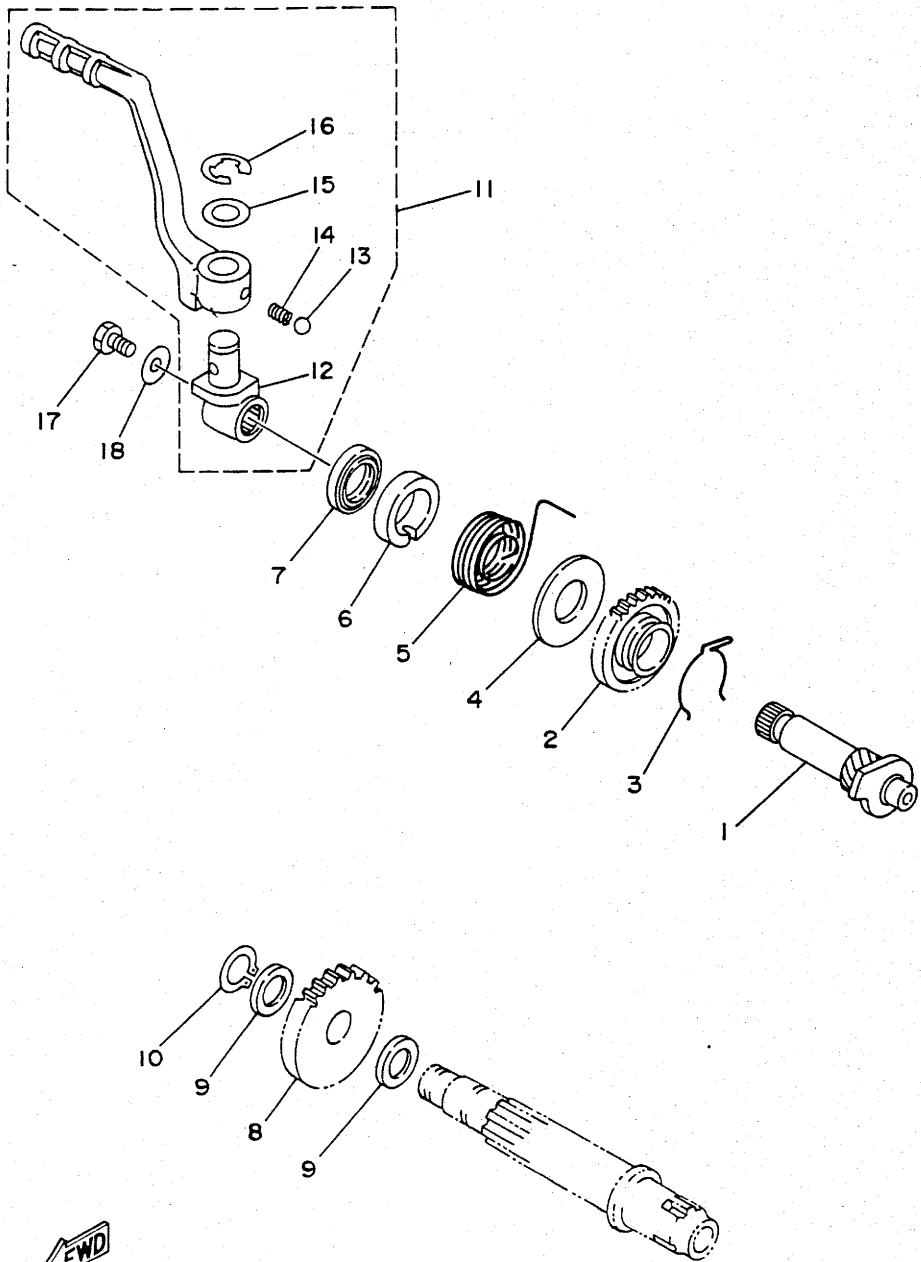

FIG. 10 STARTER

REF. NO.	PART NO.	DESCRIPTION	Q'TY	REMARKS
1	4ES-15660-00	KICK AXLE ASSY	1	
2	4ES-15641-00	GEAR, KICK	1	
3	90468-23194	CLIP	1	
4	90201-176L4	WASHER, PLATE	1	
5	90508-26750	SPRING, TORSION	1	
6	4ES-15664-00	GUIDE, SPRING	1	
7	93102-17263	OIL SEAL	1	
8	4ES-15651-00	GEAR, KICK IDLE	1	
9	90201-124F8	WASHER, PLATE	2	
10	99009-12400	CIRCLIP	1	
11	4ES-15620-00	KICK CRANK ASSY	1	
12	4ES-15621-00	.BOSS, KICK CRANK	1	
13	93507-32031	.BALL	1	
14	90501-12081	.SPRING, COMPRESSION	1	
15	90201-12631	.WASHER, PLATE	1	
16	93430-08007	.CIRCLIP	1	
17	95023-06012	BOLT	1	
18	90201-065F3	WASHER, PLATE	1	

4ES1100-3100

B12

FIG. 11 CLUTCH

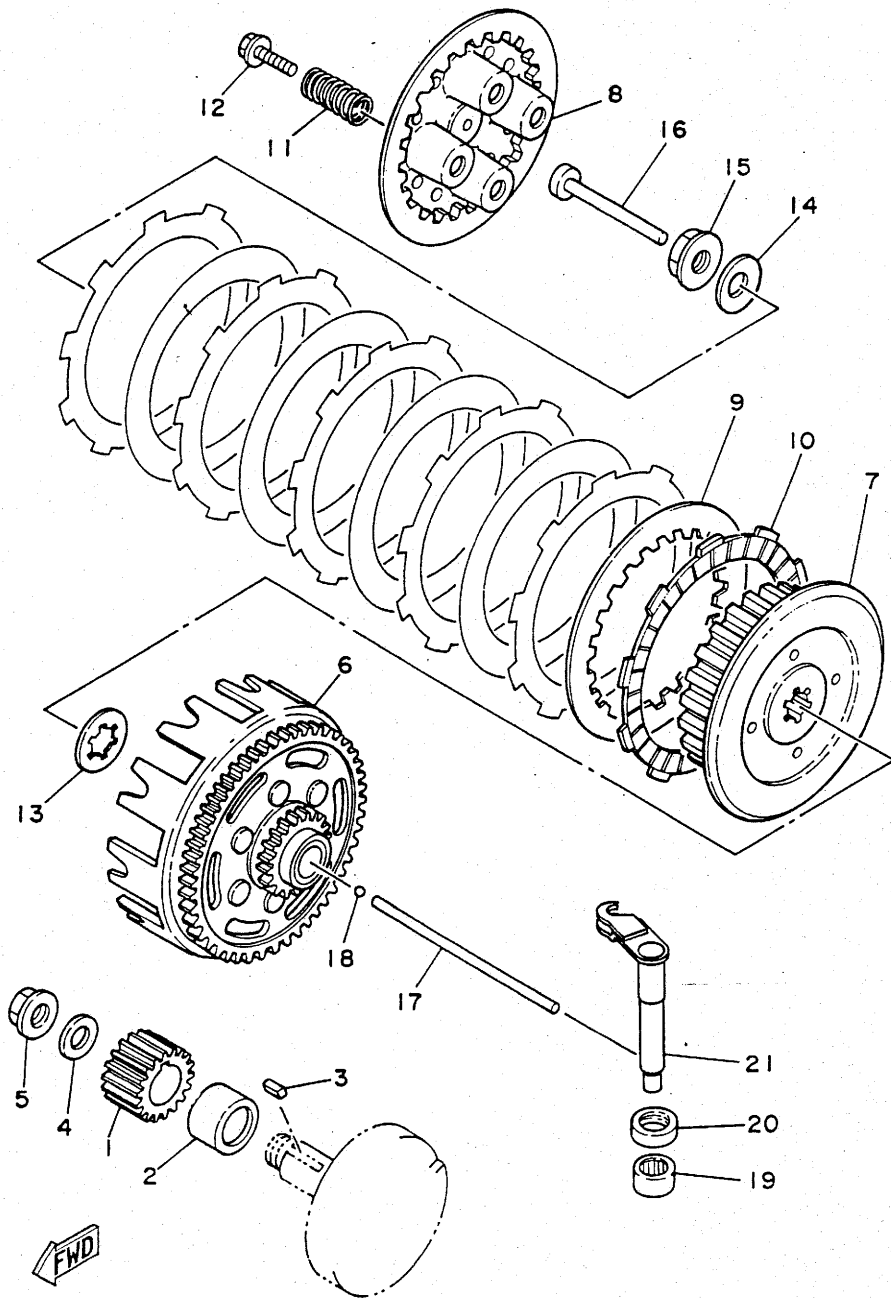

4ES1100-3110

REF. NO.	PART NO.	DESCRIPTION	Q'TY	REMARKS
1	4ES-16111-00	GEAR, PRIMARY DRIVE	1	
2	90387-20488	COLLAR	1	
3	90282-05001	KEY, STRAIGHT	1	
4	90208-12015	WASHER, CONICAL SPRING	1	
5	90179-12244	NUT	1	
6	4ES-16150-00	PRIMARY DRIVEN GEAR COMP.	1	
7	1LR-16371-00	BOSS, CLUTCH	1	
8	1LR-16351-00	PLATE, PRESSURE 1	1	
9	257-16324-00	PLATE, CLUTCH 1	5	
10	4ES-16321-00	PLATE, FRICTION	6	
11	90501-20361	SPRING, COMPRESSION	4	
12	90159-05011	SCREW, WITH WASHER	4	
13	4V0-16154-00	PLATE, THRUST 1	1	
14	90208-12015	WASHER, CONICAL SPRING	1	
15	90179-12244	NUT	1	
16	4ES-16356-00	ROD, PUSH 1	1	
17	2X3-16357-00	ROD, PUSH 2	1	
18	93503-16010	BALL	1	
19	93315-11206	BEARING, CYLINDRICAL	1	
20	93102-12224	OIL SEAL	1	
21	4ES-16381-00	PUSH LEVER COMP.	1	

B13

FIG. 12 TRANSMISSION

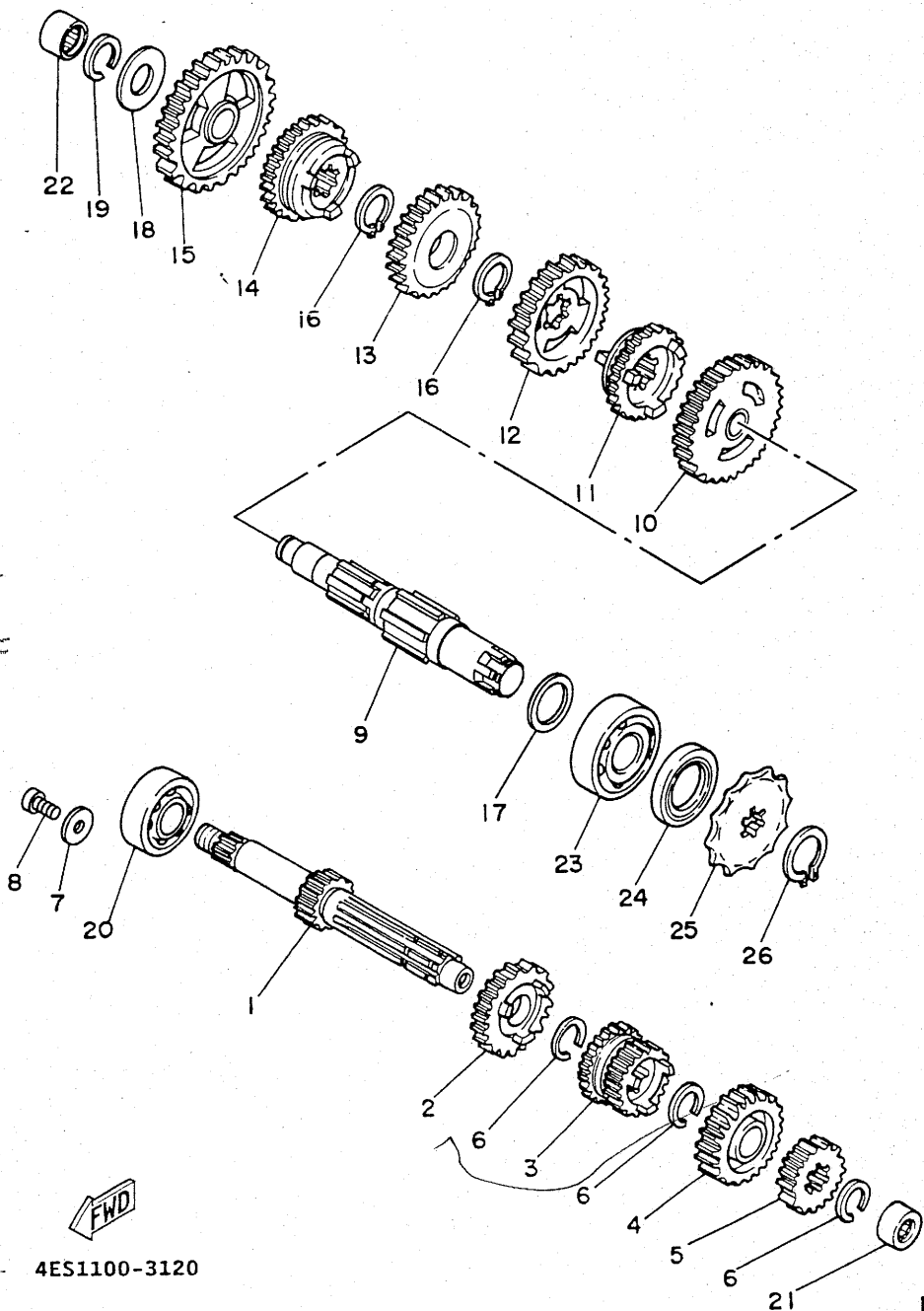

REF. NO.	PART NO.	DESCRIPTION	Q'TY	REMARKS
1	4ES-17411-00	AXLE, MAIN	1	
2	4ES-17151-00	GEAR, 5TH PINION	1	
3	4ES-17131-00	GEAR, 3RD PINION	1	
4	4ES-17161-00	GEAR, 6TH PINION	1	
5	4ES-17121-00	GEAR, 2ND PINION	1	
6	93440-17064	CIRCLIP	3	
7	90201-065F3	WASHER, PLATE	2	
8	90157-06071	SCREW, PAN HEAD	2	
9	4ES-17421-00	AXLE, DRIVE	1	
10	4ES-17221-00	GEAR, 2ND WHEEL	1	
11	4ES-17261-00	GEAR, 6TH WHEEL	1	
12	4ES-17231-00	GEAR, 3RD WHEEL	1	
13	4ES-17241-00	GEAR, 4TH WHEEL	1	
14	4ES-17251-00	GEAR, 5TH WHEEL	1	
15	4ES-17211-00	GEAR, 1ST WHEEL	1	
16	93410-20038	CIRCLIP	2	
17	90201-203E7	WASHER, PLATE	1	
18	164-17427-00-06	SHIM 1 (0.6T)	1	
19	93440-15012	CIRCLIP	1	
20	93306-20333	BEARING	1	
21	93317-11245	BEARING, CYLINDRICAL	1	
22	93315-31502	BEARING, CYLINDRICAL	1	
23	93306-20421	BEARING (B6204)	1	
24	93102-20143	OIL SEAL	1	
25	93822-14037	SPROCKET, DRIVE 14T (1741746140)	1	STD
	93822-12012	SPROCKET, DRIVE 12T (1741746120)	1	AP
	93822-13024	SPROCKET, DRIVE 13T (1741746130)	1	AP
	93822-15065	SPROCKET, DRIVE 15T (1741746150)	1	AP

B14

FIG. 12 TRANSMISSION

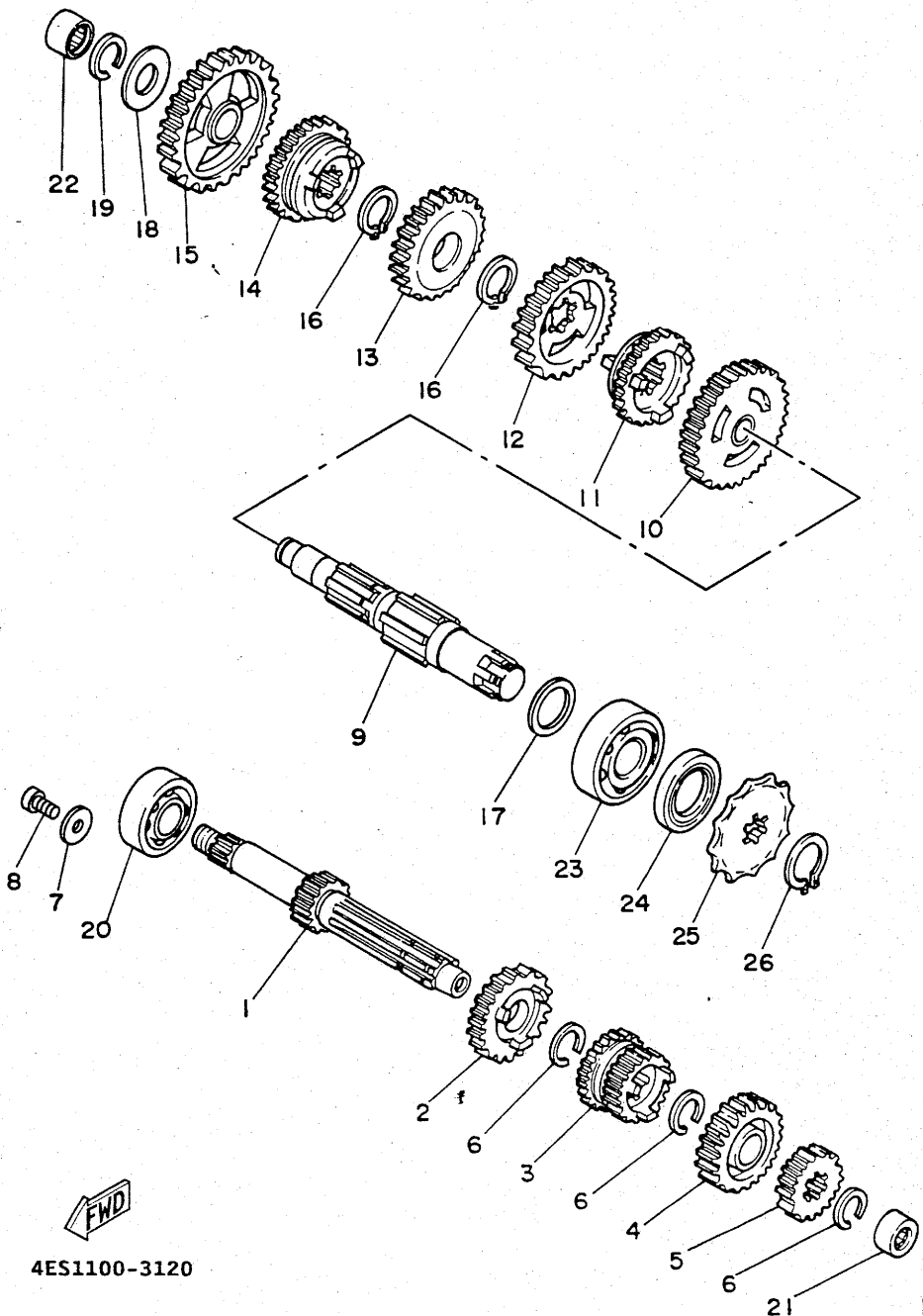

REF. NO.	PART NO.	DESCRIPTION	Q'TY	REMARKS
26	99009-18400	CIRCLIP	1	

FWD
4ES1100-3120

B15

FIG. 13 SHIFT CAM. FORK

REF. NO.	PART NO.	DESCRIPTION	Q'TY	REMARKS
1	4ES-18540-00	SHIFT CAM ASSY	1	
2	4ES-18511-00	FORK, SHIFT 1	1	
3	4V0-18512-00	FORK, SHIFT 2	1	
4	4ES-18513-00	FORK, SHIFT 3	1	
5	90250-06013	PIN, STRAIGHT	3	
6	4BA-18531-00	BAR, SHIFT FORK GUIDE 1	1	
7	4BA-18535-00	BAR, SHIFT FORK GUIDE 2	1	

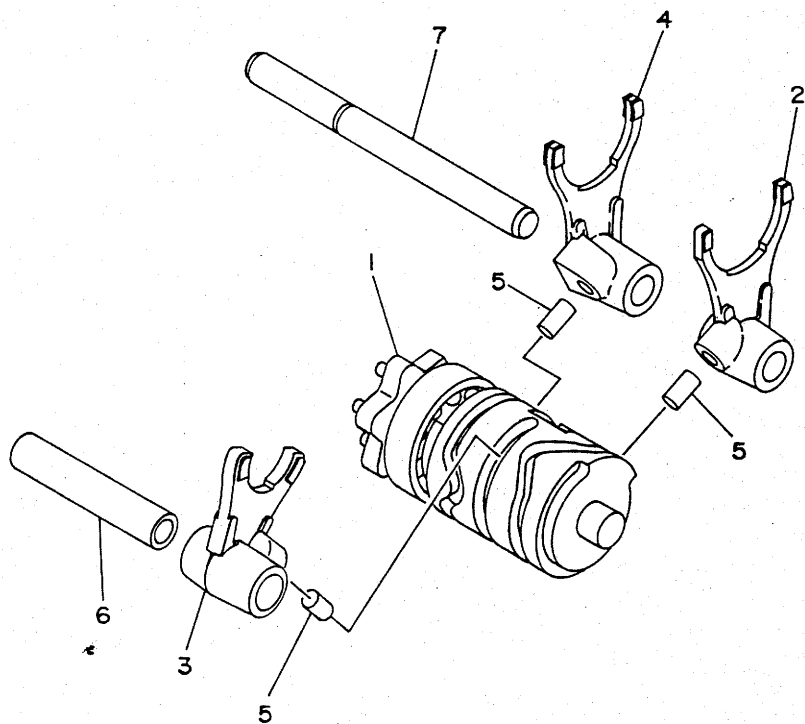

4ES1100-3130

C2

FIG. 14 SHIFT SHAFT

REF. NO.	PART NO.	DESCRIPTION	Q'TY	REMARKS
1	4ES-18101-00	SHIFT SHAFT ASSY	1	
2	90508-32553	SPRING, TORSION	1	
3	90508-242A6	SPRING, TORSION	1	
4	90387-126Y7	COLLAR	1	
5	99006-10600	CIRCLIP	3	
6	4BA-18140-00	STOPPER LEVER ASSY	1	
7	93101-12060	OIL SEAL	1	
8	2HF-18110-01	SHIFT PEDAL ASSY	1	
9	97011-06020	BOLT	1	

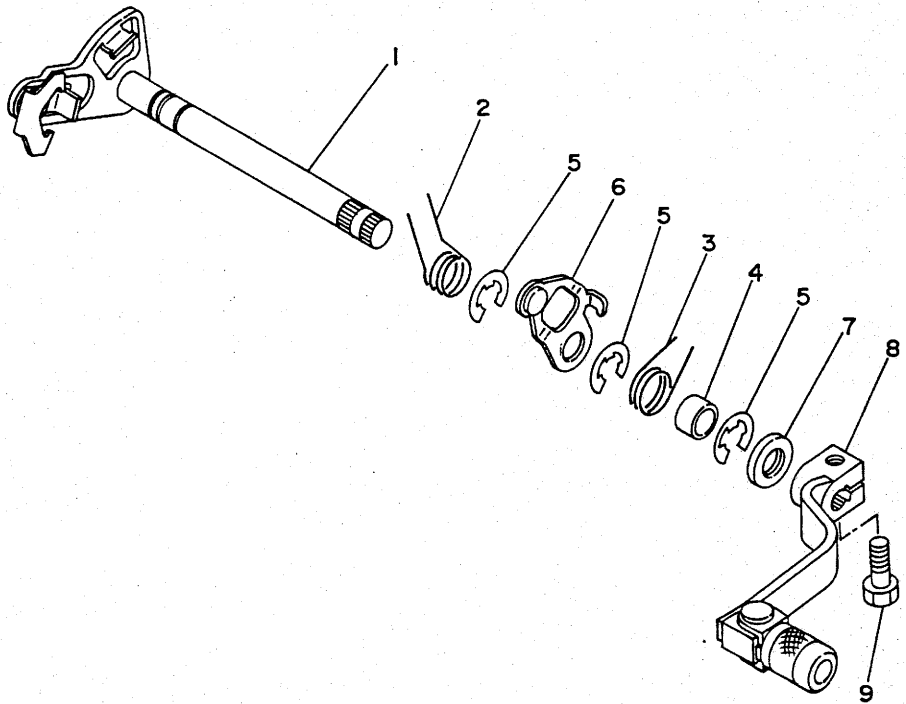

4ES1100-3140

C3

FIG. 15 FRAME

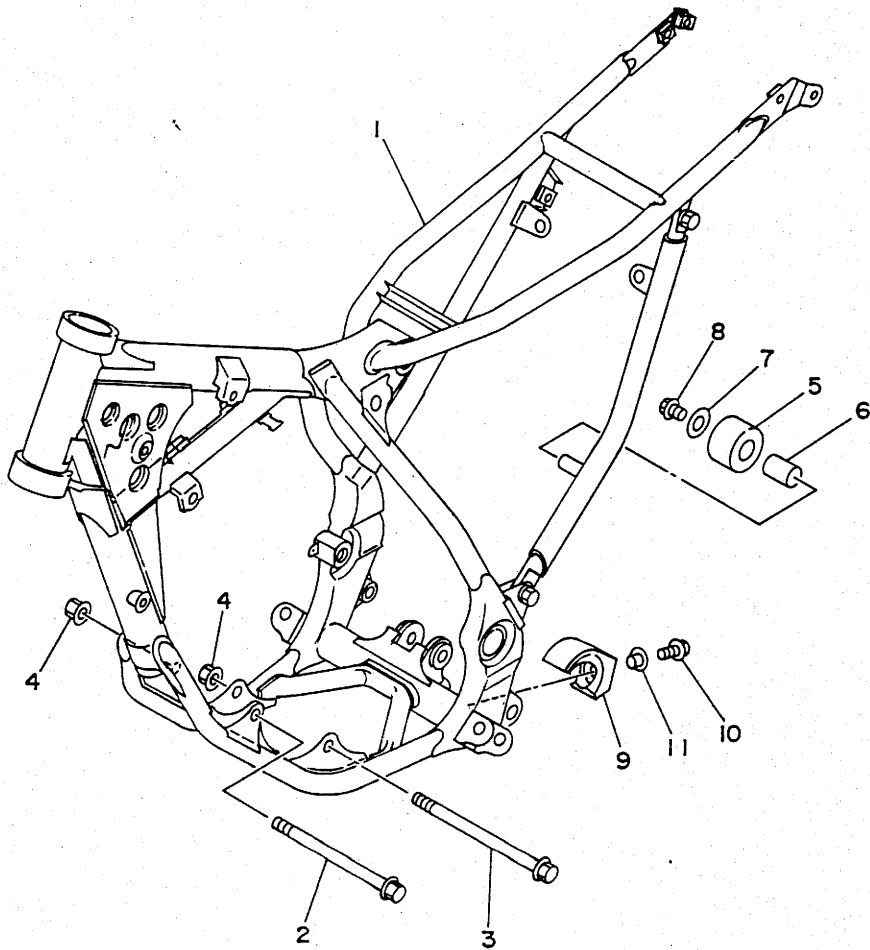

REF. NO.	PART NO.	DESCRIPTION	Q'TY	REMARKS
1	4ES-21110-00-UJ	FRAME COMP.	1	RADICAL WHITE
2	91011-08125	BOLT, FLANGE	1	
3	91011-08135	BOLT, FLANGE	1	
4	95601-08200	NUT, SELF-LOCKING	2	
5	30X-22178-00	TENSIONER	1	
6	4V4-22184-00	BUSH	1	
7	90201-081R9	WASHER, PLATE	1	
8	95023-08012	BOLT	1	
9	4ES-22178-00	TENSIONER	1	
10	90119-06118	BOLT, WITH WASHER	1	
11	90387-06216	COLLAR	1	



4ES1100-3150

C4

FIG. 16 FENDER

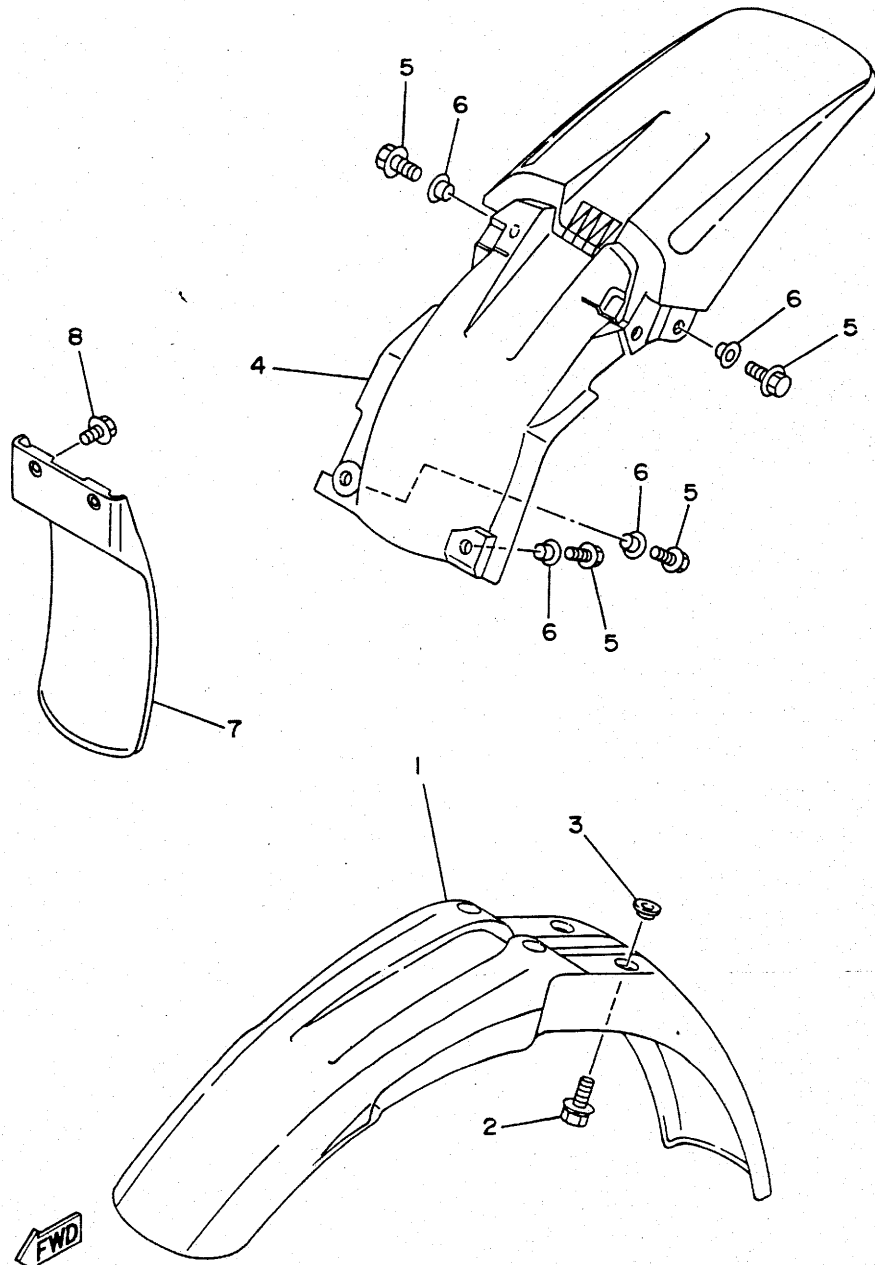

REF. NO.	PART NO.	DESCRIPTION	Q'TY	REMARKS
1	4ES-21511-00	FENDER, FRONT	1	
2	90119-06063	BOLT, WITH WASHER	4	
3	90209-06187	WASHER	4	
4	4ES-21611-00	FENDER, REAR	1	
5	95023-06016	BOLT	4	
6	90387-064X4	COLLAR	4	
7	4ES-21642-00	GUARD, FLAP	1	
8	90119-06185	BOLT, WITH WASHER	2	

4ES1100-3160

C5

FIG. 17 SIDE COVER

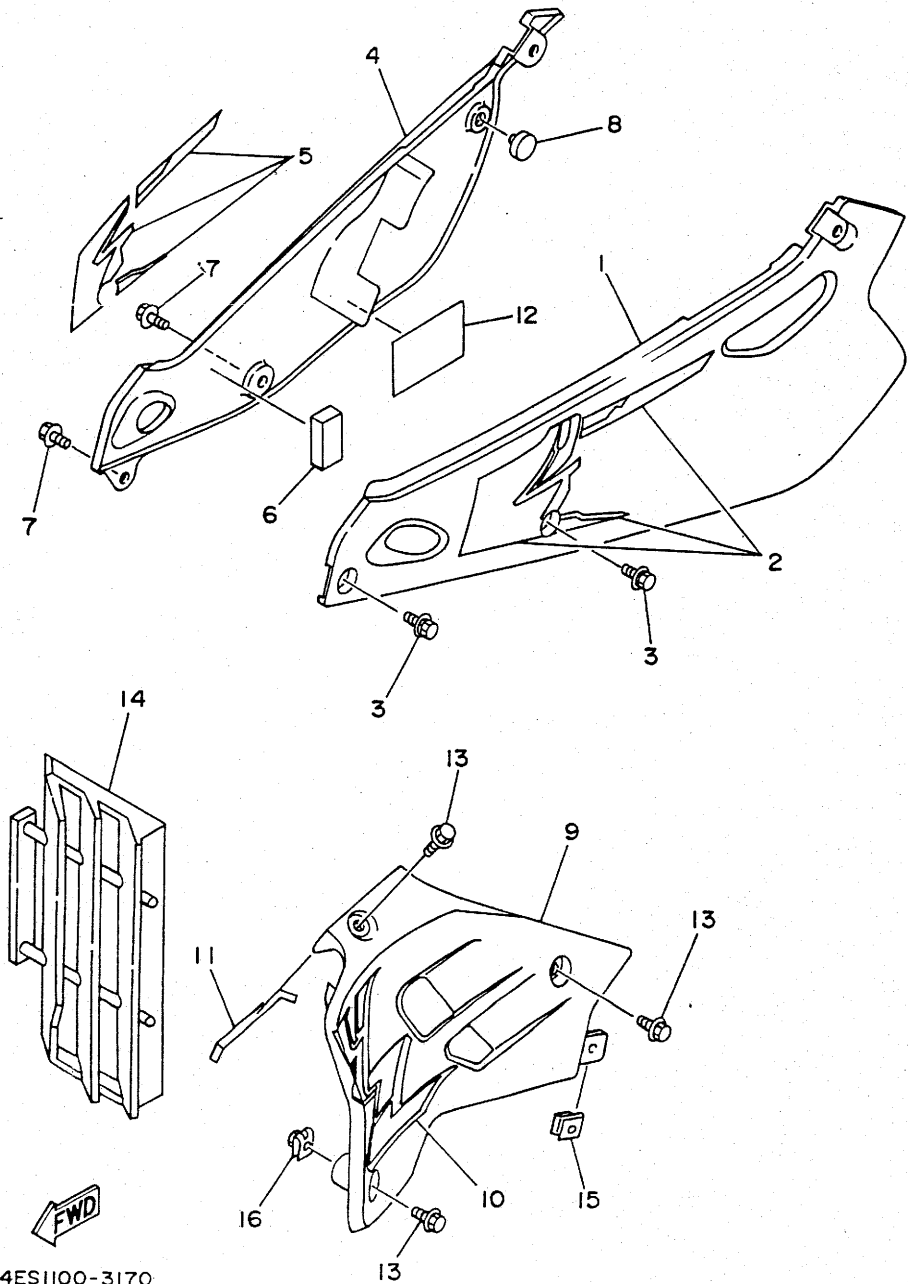

REF. NO.	PART NO.	DESCRIPTION	Q'TY	REMARKS
1	4ES-21711-00	COVER, SIDE 1	1	
2	4ES-2173L-01	GRAPHIC SET 1	1	
3	90119-06217	BOLT, WITH WASHER	2	
4	4ES-21721-00	COVER, SIDE 2	1	
5	4ES-2174L-01	GRAPHIC SET 2	1	
6	4ES-21735-00	SEAL 2	1	
7	90119-06217	BOLT, WITH WASHER	2	
8	22W-24181-00	DAMPER, LOCATING 1	1	
9	4ES-21731-00	COVER, SIDE 3	1	
10	4ES-21783-01	EMBLEM 3	1	
11	4ES-21732-00	SEAL 1	1	
12	4DJ-2174A-00	INSULATOR, SIDE COVER	1	
13	90109-067F4	BOLT	3	
14	4EW-2172A-00	PANEL 1	1	
15	90183-06023	NUT, SPRING	1	
16	90183-06069	NUT, SPRING	1	

4ES1100-3170

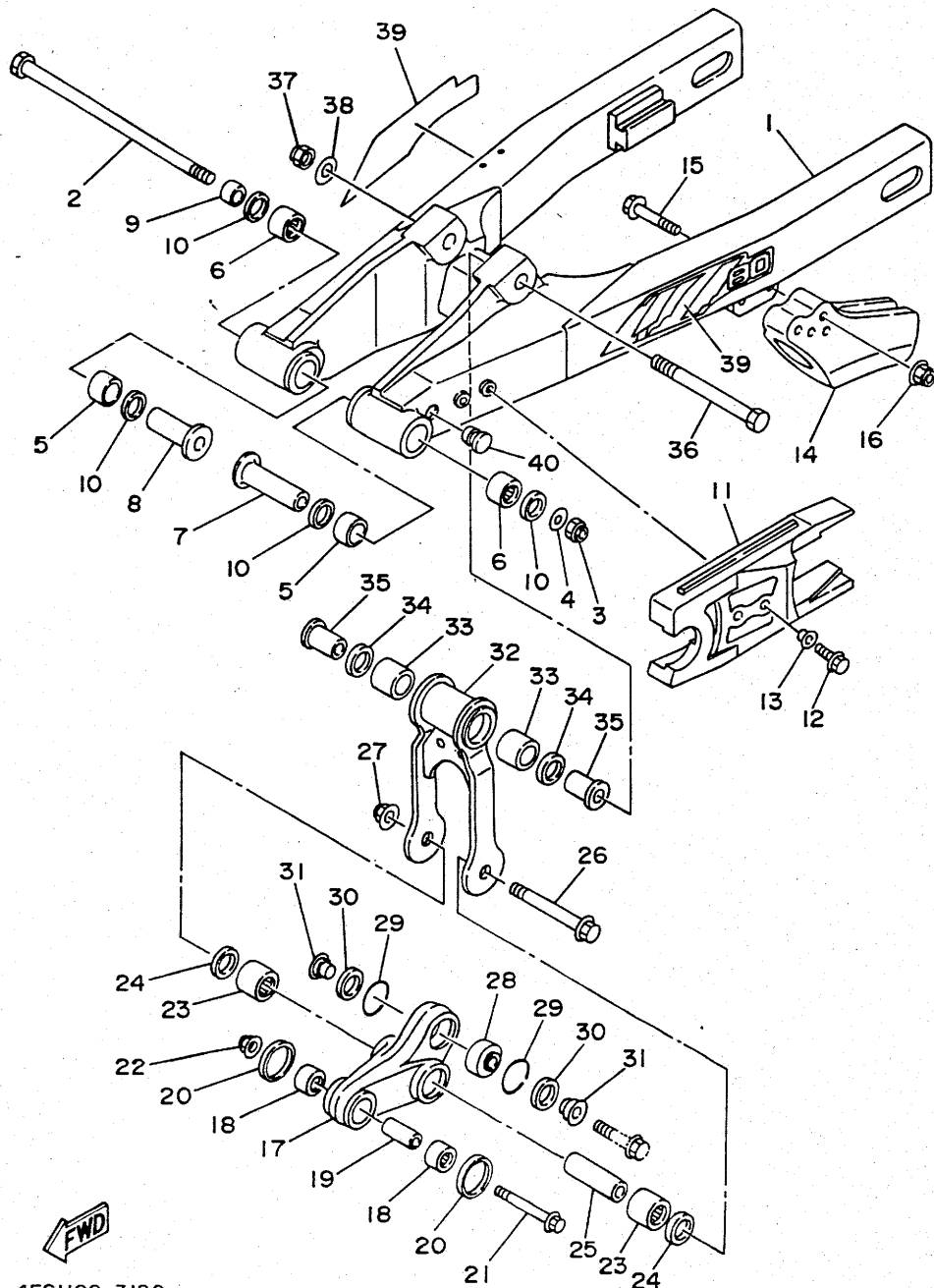

4ES1100-3180

FIG. 18 REAR ARM

REF. NO.	PART NO.	DESCRIPTION	Q'TY	REMARKS
1	4ES-22110-00	REAR ARM COMP.	1	
2	22W-25181-01	AXLE, WHEEL	1	
3	90185-12119	NUT, SELF-LOCKING	1	
4	90201-12469	WASHER, PLATE	1	
5	90385-17042	BUSH	2	
6	93317-21746	BEARING, CYLINDRICAL	2	
7	90387-127J8	COLLAR	1	
8	90387-127J7	COLLAR	1	
9	90387-1200U	COLLAR	1	
10	93109-17048	OIL SEAL (SDO 17-24-4)	4	
11	4ES-22151-00	SEAL, GUARD	1	
12	95021-06014	BOLT, FLANGE	2	
13	90387-062X0	COLLAR	2	
14	39K-22199-00	SUPPORT, CHAIN	1	
15	90105-08310	BOLT, WASHER BASED	2	
16	95601-08200	NUT, SELF-LOCKING	2	
17	4ES-2217A-00	ARM, RELAY	1	
18	93315-31449	BEARING, CYLINDRICAL	2	
19	90380-10218	BUSH, SOLID	1	
20	4ES-22129-00	COVER, THRUST 2	2	
21	90105-10582	BOLT, WASHER BASED	1	
22	95601-10200	NUT, SELF-LOCKING	1	
23	93315-31748	BEARING, CYLINDRICAL	2	
24	93101-17062	OIL SEAL	2	
25	90380-12219	BUSH, SOLID	1	
26	90105-12382	BOLT, WASHER BASED	1	
27	95601-12200	NUT, SELF-LOCKING	1	
28	93399-99921	BEARING	1	

C7

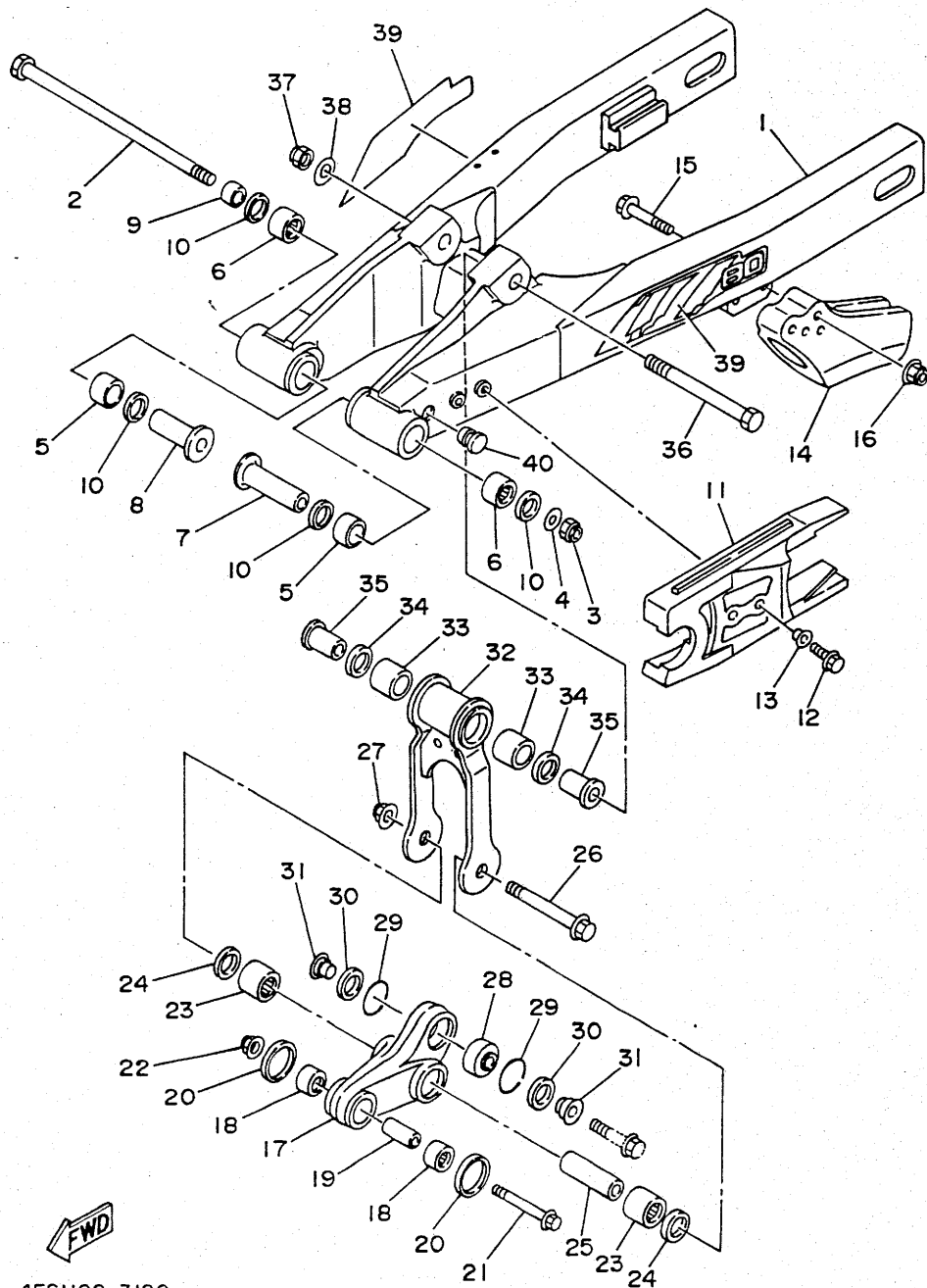

FIG. 18 REAR ARM

REF. NO.	PART NO.	DESCRIPTION	Q'TY	REMARKS
29	93440-30113	CIRCLIP	2	
30	3XJ-22475-00	SEAL, DUST	2	
31	90387-103X9	COLLAR	2	
32	4ES-2217F-00	ROD, CONNECTING 1	1	
33	93315-31748	BEARING, CYLINDRICAL	2	
34	93101-17062	OIL SEAL	2	
35	90381-12091	BUSH, SOLID	2	
36	90101-12755	BOLT	1	
37	90185-12119	NUT, SELF-LOCKING	1	
38	90201-122A7	WASHER, PLATE	1	
39	4ES-22180-01	EMBLEM	1	
40	90338-10150	PLUG	2	

4ES1100-3180

C8

FIG. 19 REAR SUSPENSION

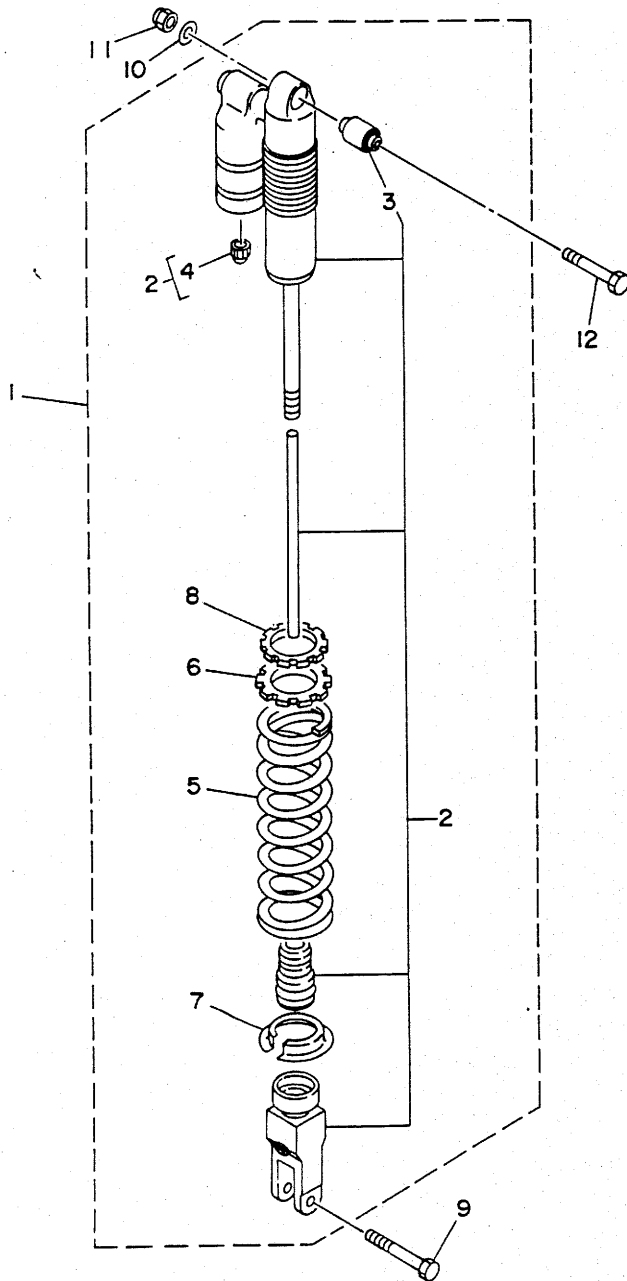

REF. NO.	PART NO.	DESCRIPTION	Q'TY	REMARKS
1	4ES-22210-00	SHOCK ABSORBER ASSY, REAR	1	UR FOR USA
	4ES-22210-10	SHOCK ABSORBER ASSY, REAR	1	UR FOR CANADA
	4ES-22210-20	SHOCK ABSORBER ASSY, REAR	1	UR FOR NEWZEALAND, S.AFRICA
2	4ES-22201-00	.DAMPER SUB ASSY	1	UR FOR USA
	4ES-22201-10	.DAMPER SUB ASSY	1	UR FOR CANADA
	4ES-22201-20	.DAMPER SUB ASSY	1	UR FOR NEWZEALAND, S.AFRICA
3	4ES-22124-00	..BUSH 2	1	
4	58T-23184-L0	..CAP, AIR VALVE	1	
5	4ES-22212-00	.SPRING (K=5.0)	1	
6	4ES-22214-00	.GUIDE, SPRING 1	1	
7	3JD-22214-00	.GUIDE, SPRING 1	1	
8	4ES-22251-00	.NUT 1	1	
9	90109-10729	BOLT	1	
10	92990-10600	WASHER, PLATE	1	
11	90185-10120	NUT, SELF-LOCKING	1	
12	90105-10614	BOLT, WASHER BASED	1	



4ES1100-3190

C9

FIG. 20 STEERING

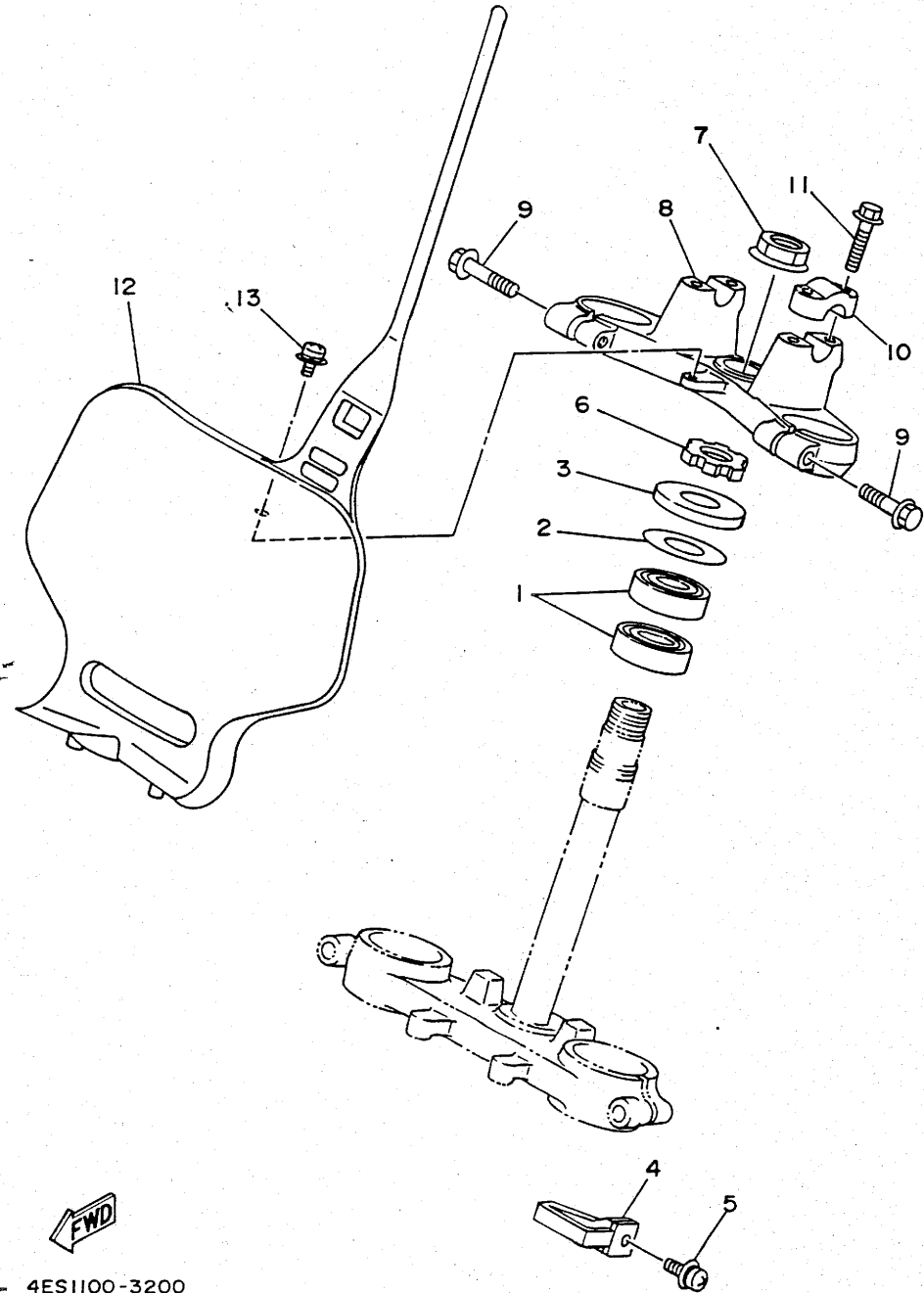

REF. NO.	PART NO.	DESCRIPTION	Q'TY	REMARKS
1	93332-00079	BEARING	2	
2	90201-256K5	WASHER, PLATE (0.5T)	1	
3	1J7-23415-00	COVER, BALL RACE 1	1	
4	4DA-23389-00	GUIDE, CABLE	1	
5	90159-05122	SCREW, WITH WASHER	1	
6	90179-25033	NUT	1	
7	90179-22412	NUT	1	
8	4ES-23435-00	CROWN, HANDLE	1	
9	95811-08035	BOLT, FLANGE	2	
10	3SP-23441-00	HOLDER, HANDLE UPPER	2	
11	95023-08030	BOLT	4	
12	4ES-23485-00	PLATE, NUMBER	1	
13	95023-06012	BOLT	1	



4ES1100-3200

C10

FIG. 21 FRONT FORK

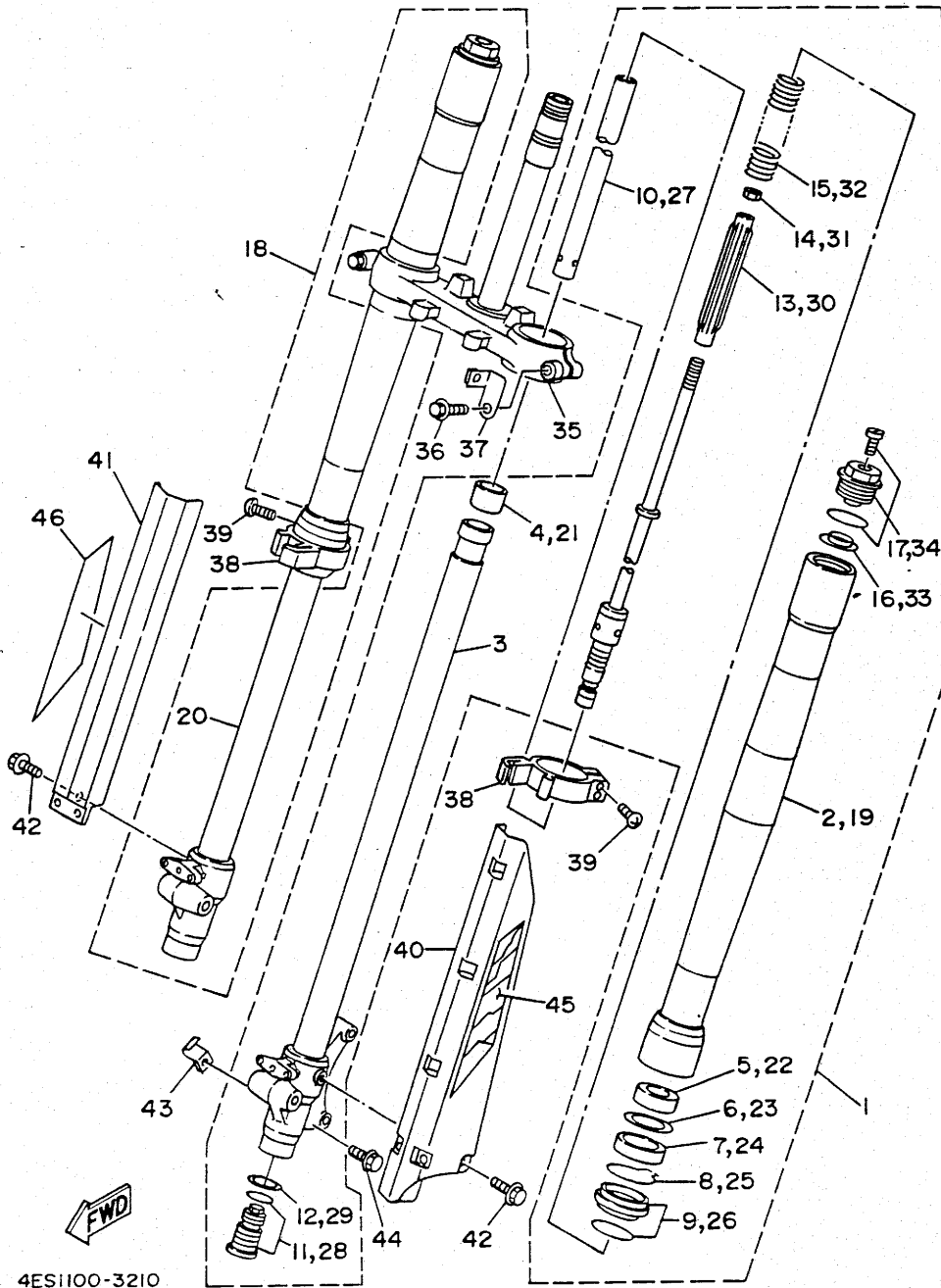

REF. NO.	PART NO.	DESCRIPTION	Q'TY	REMARKS
1	4ES-23102-00	FRONT FORK ASSY (L.H)	1	
2	4ES-23136-00	.TUBE, OUTER (RIGHT)	1	
3	4ES-23120-00	.INNER TUBE COMP. 2	1	
4	4ES-23171-00	.PISTON, FRONT FORK	1	
5	4ES-23125-00	.METAL, SLIDE 1	1	
6	5K5-23149-00	.WASHER, SPRING UPPER	1	
7	4ES-23145-00	.OIL SEAL	1	
8	4A1-23156-00	.CLIP, OIL SEAL	1	
9	4ES-23144-00	.SEAL, DUST	1	
10	4ES-23170-00	.CYLINDER COMP., FRONT FORK	1	
11	4ES-2316A-00	.VALVE COMP.	1	
12	2HH-23158-L0	.GASKET	1	
13	4ES-23142-00	.SEAT, SPRING UPPER	1	
14	3XJ-23357-L0	.NUT	1	
15	4ES-23141-00	.SPRING, FRONT FORK	1	
16	3GM-23142-00	.SEAT, SPRING UPPER	1	
17	4ES-23111-00	.BOLT, CAP	1	
18	4ES-23103-00	FRONT FORK ASSY (R.H)	1	
19	4ES-23136-00	.TUBE, OUTER (RIGHT)	1	
20	4ES-23110-00	.INNER TUBE COMP. 1	1	
21	4ES-23171-00	.PISTON, FRONT FORK	1	
22	4ES-23125-00	.METAL, SLIDE 1	1	
23	5K5-23149-00	.WASHER, SPRING UPPER	1	
24	4ES-23145-00	.OIL SEAL	1	
25	4A1-23156-00	.CLIP, OIL SEAL	1	
26	4ES-23144-00	.SEAL, DUST	1	
27	4ES-23170-00	.CYLINDER COMP., FRONT FORK	1	
28	4ES-2316A-00	.VALVE COMP.	1	

4ES1100-3210

C11

FIG. 21 FRONT FORK

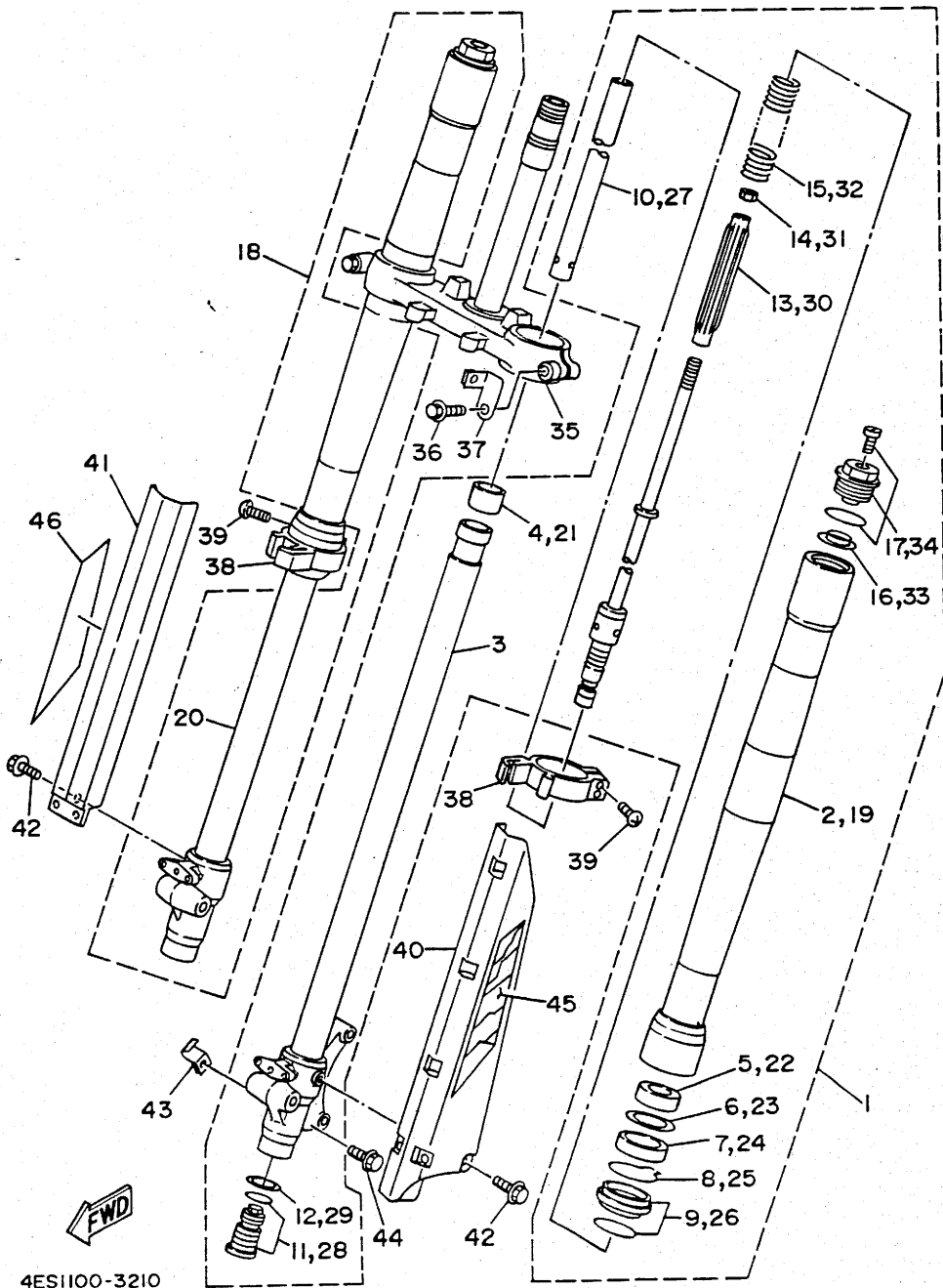

REF. NO.	PART NO.	DESCRIPTION	QTY	REMARKS
29	2HH-23158-L0	.GASKET	1	
30	4ES-23142-00	.SEAT, SPRING UPPER	1	
31	3XJ-23357-L0	.NUT	1	
32	4ES-23141-00	.SPRING, FRONT FORK	1	
33	3GM-23142-00	.SEAT, SPRING UPPER	1	
34	4ES-23111-00	.BOLT, CAP	1	
35	4ES-23340-00	UNDER BRACKET COMP.	1	
36	95021-10040	BOLT, FLANGE	2	
37	4ES-2331E-00	GUIDE, CABLE	1	
38	4ES-2314F-00	PROTECTOR GUIDE COMP. 1	2	
39	4V4-23194-L0	SCREW, BOOT BAND	4	
40	4ES-2314H-L1	PROTECTOR COMP. 1	1	
41	4ES-2314J-L0	PROTECTOR COMP. 2	1	
42	4DA-23346-L0	BOLT 1	6	
43	4ES-23318-00	HOLDER, CABLE 1	1	
44	95023-06016	BOLT	1	
45	4ES-2313B-01	EMBLEM1	1	
46	4ES-2313C-01	EMBLEM2	1	

4ES1100-3210

C12

FIG. 22 FUEL TANK

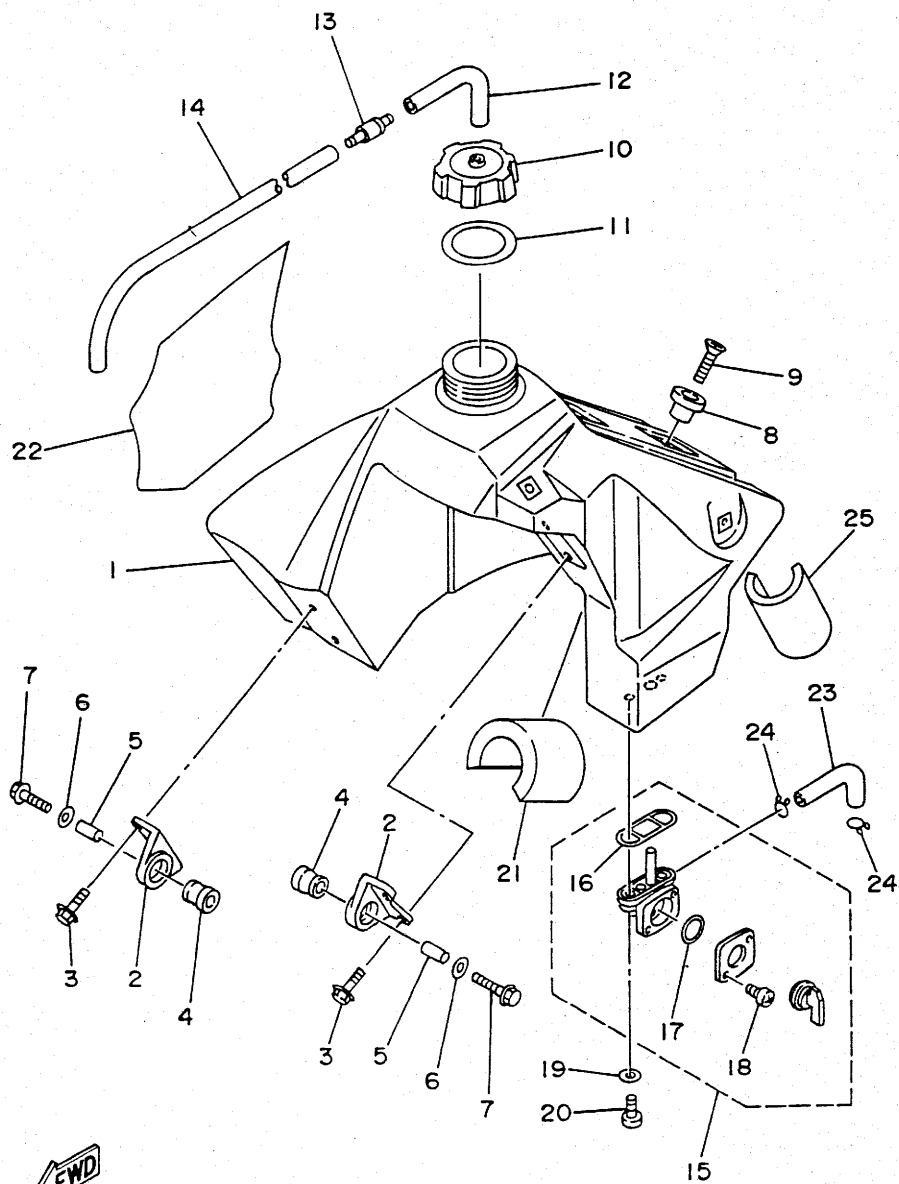

REF. NO.	PART NO.	DESCRIPTION	Q'TY	REMARKS
1	4ES-24110-00	FUEL TANK COMP.	1	
2	24X-24144-00	HOLDER, DAMPER	2	
3	95023-06016	BOLT	4	
4	90480-18549	GROMMET	2	
5	90387-06027	COLLAR	2	
6	90201-06697	WASHER, PLATE	2	
7	95023-06030	BOLT	2	
8	4EW-2412F-00	BRACKET, SEAT	1	
9	98701-06025	SCREW, FLAT HEAD	1	
10	5X7-24611-01	BODY, CAP	1	
11	5X7-24612-00	GASKET, CAP	1	
12	90445-09055	HOSE	1	
13	3XJ-24380-00	PIPE JOINT ASSY	1	
14	90445-09100	HOSE	1	
15	2VN-24500-01	FUEL COCK ASSY 1	1	
16	4X8-24512-00	.O-RING	1	
17	3AJ-24534-00	.SEAL, COCK	1	
18	98580-03008	.SCREW, PAN HEAD	2	
19	90202-05193	WASHER, PLATE	2	
20	90149-06011	SCREW	2	
21	3Y0-24183-00	DAMPER, LOCATING 3	1	
22	4ES-24161-00	EMBLEM 1	1	
23	4ES-24311-00	PIPE, FUEL 1	1	
24	90467-10008	CLIP	2	
25	51L-28371-00	DAMPER	1	

4ES1100-3220

C13

FIG. 23 SEAT

REF. NO.	PART NO.	DESCRIPTION	Q'TY	REMARKS
1	4ES-24770-00	SEMI-DOUBLE SEAT ASSY	1	DEEP VIOLET SOLID 1
2	4ES-24731-00	.COVER, SEAT	1	DEEP VIOLET SOLID 1
3	95023-06020	BOLT	2	
4	92901-06200	WASHER, PLAIN	2	

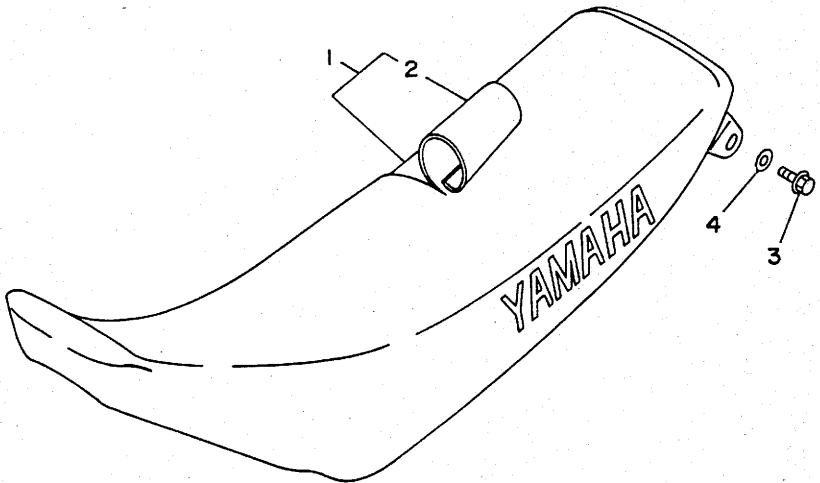

4ES1100-3230

C14

FIG. 24 FRONT WHEEL

REF. NO.	PART NO.	DESCRIPTION	Q'TY	REMARKS
1	4ES-25111-00	HUB, FRONT	1	
2	90387-124H0	COLLAR	1	
3	93306-20117	BEARING	2	
4	93106-20031	OIL SEAL	2	
5	94107-177Y5	TIRE (70/100-17 40M K490)	1	DUNLOP
6	94207-17284	TUBE (70/100-17 TR4)	1	DUNLOP
7	94307-17166	BAND, RIM (80/90,70/100-17)	1	DUNLOP
8	94414-17516	RIM (1.40-17)	1	
9	4ES-25104-00	SPOKE SET, FRONT	1	
10	1T1-25194-00	SPACER, BEAD	1	
11	4ES-25181-00	AXLE, WHEEL	1	
12	90185-12046	NUT, SELF-LOCKING	1	
13	90201-12362	WASHER, PLATE	2	
14	4ES-25183-10	COLLAR, WHEEL	2	

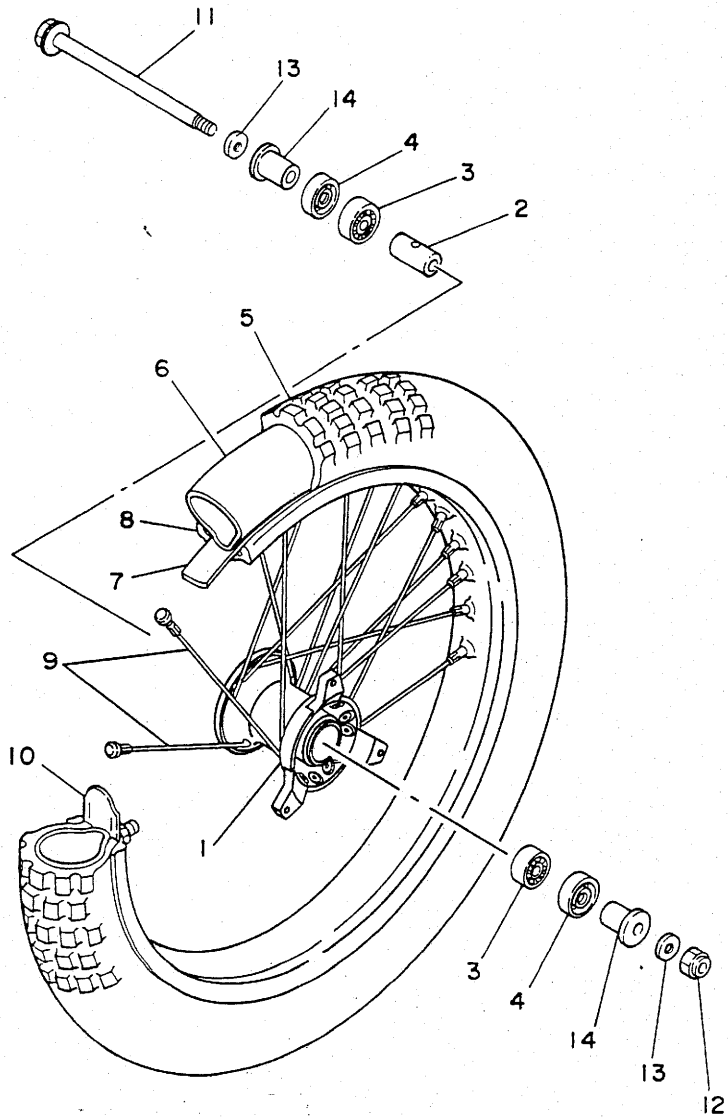

4ES1100-3240

C15

FIG. 25 FRONT BRAKE CALIPER

REF. NO.	PART NO.	DESCRIPTION	Q'TY	REMARKS
1	4ES-2582T-00	DISC, BRAKE	1	
2	90149-06272	SCREW	3	
3	4ES-2580T-00	CALIPER ASSY (LEFT)	1	
4	1LR-W0057-00	.PISTON ASSY, CALIPER	1	
5	1LR-W0047-00	..CALIPER SEAL KIT	1	
6	5R2-25937-00	.BOOT 2	1	
7	56A-25937-00	.BOOT 2	1	
8	47X-25824-00	.SCREW, BREED	1	
9	56A-25919-00	.SUPPORT, PAD	1	
10	56A-25919-10	.SUPPORT, PAD	1	
11	4ES-W0045-00	.BRAKE PAD KIT	1	
12	56A-25926-00	.BOLT	1	
13	34X-25845-00	.CAP, INDICATOR	1	
14	90105-08211	BOLT, WASHER BASED	2	

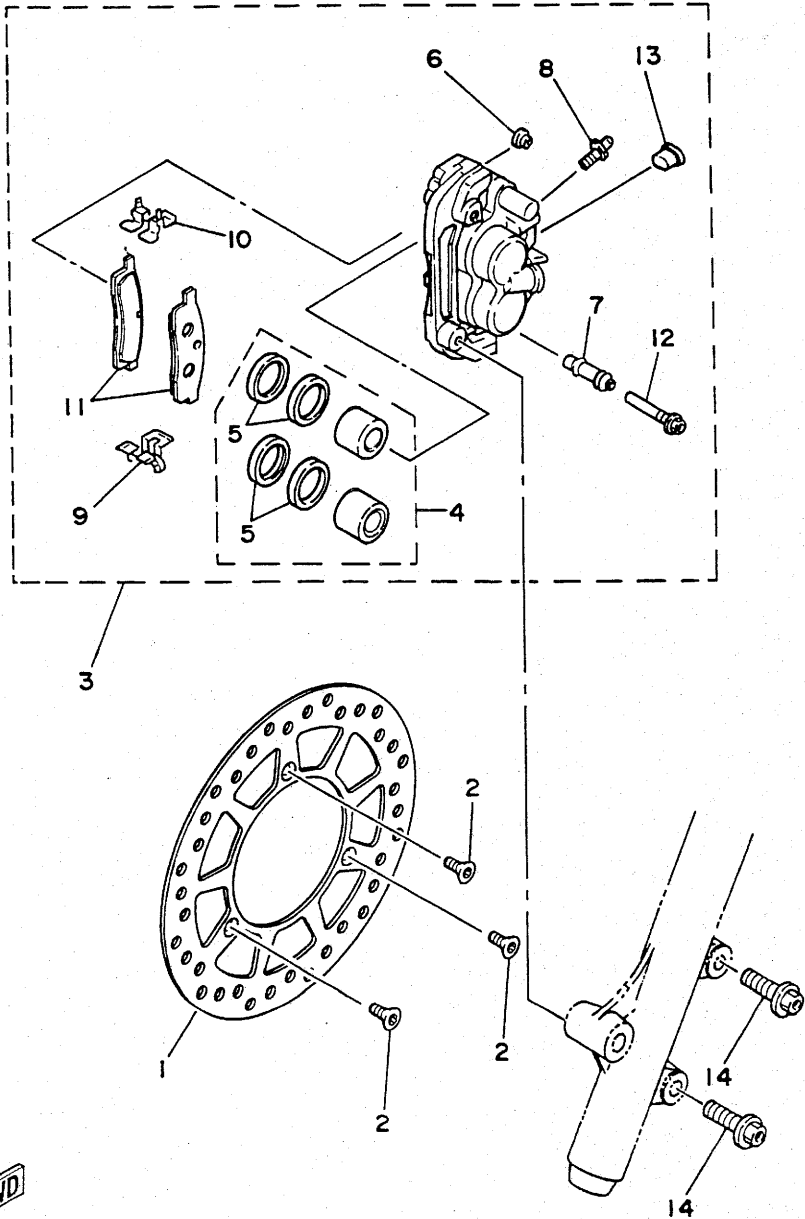

4ES1100-3250

D2

FIG. 26 REAR WHEEL

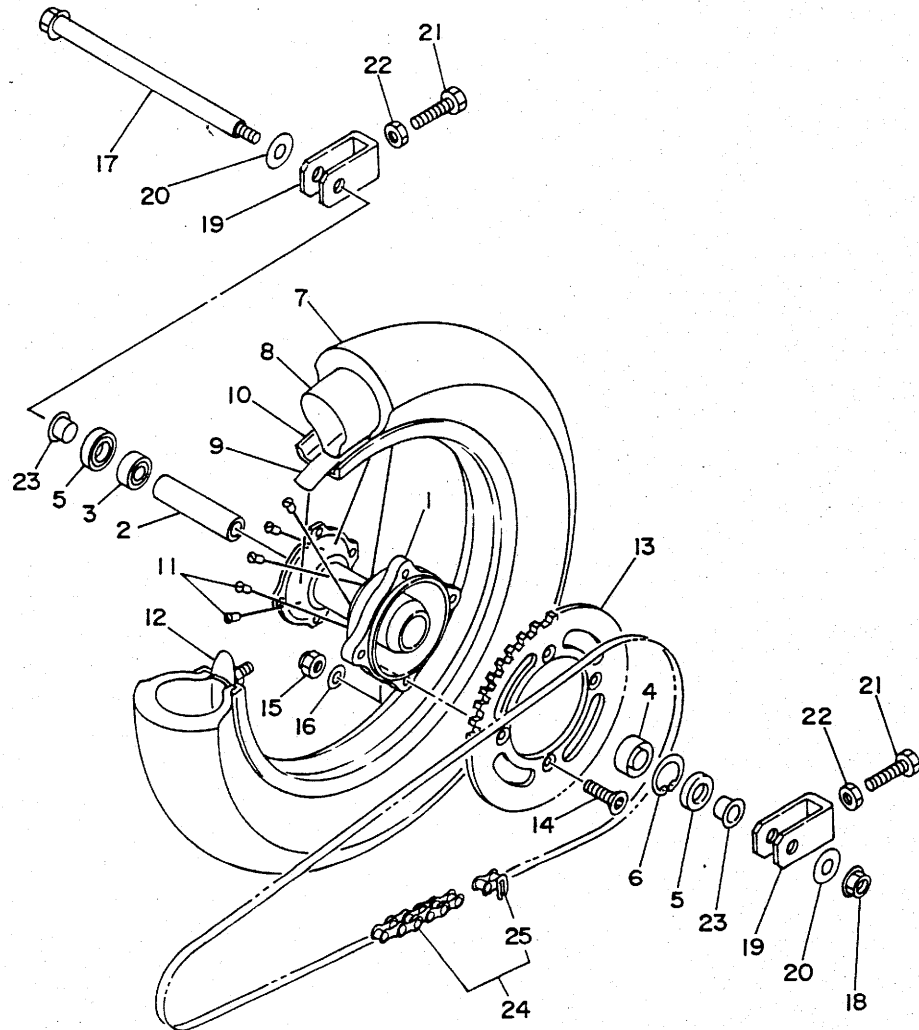

REF. NO.	PART NO.	DESCRIPTION	Q'TY	REMARKS
1	4ES-25311-00	HUB, REAR	1	
2	4ES-25383-00	COLLAR, WHEEL	1	
3	93306-00210	BEARING	1	
4	93306-20204	BEARING (B6202Z)	1	
5	93102-20009	OIL SEAL	2	
6	99009-35500	CIRCLIP	1	
7	94109-147Y6	TIRE (90/100-14 49M K695)	1	DUNLOP
8	94208-14285	TUBE (80-90/100-14 TR4)	1	DUNLOP
9	94308-14165	BAND, RIM (80-90/100-14)	1	DUNLOP
10	94416-14517	RIM (1.60-14)	1	
11	4ES-25304-00	SPOKE SET, REAR	1	
12	5X2-25394-00	SPACER, BEAD	1	
13	4ES-25447-00	SPROCKET, DRIVEN (47T)	1	STD
	4ES-25446-00	SPROCKET, DRIVEN (46T)	1	AP
	4ES-25448-00	SPROCKET, DRIVEN (48T)	1	AP
14	90109-08706	BOLT	4	
15	95611-08100	NUT, U	4	
16	90201-081A6	WASHER, PLATE	4	
17	4ES-25381-00	AXLE, WHEEL	1	
18	95601-14200	NUT, SELF-LOCKING	1	
19	4ES-25388-00	PULLER, CHAIN 1	2	
20	90201-161R1	WASHER, PLATE	2	
21	90101-08699	BOLT	2	
22	95303-08700	NUT	2	
23	4ES-25383-10	COLLAR, WHEEL	2	
24	94580-24118	CHAIN (DID428 118L)	1	
25	94680-24001	.JOINT, CHAIN (DID 428)	1	

4ES1100-3260

D3

FIG. 27 REAR BRAKE CALIPER

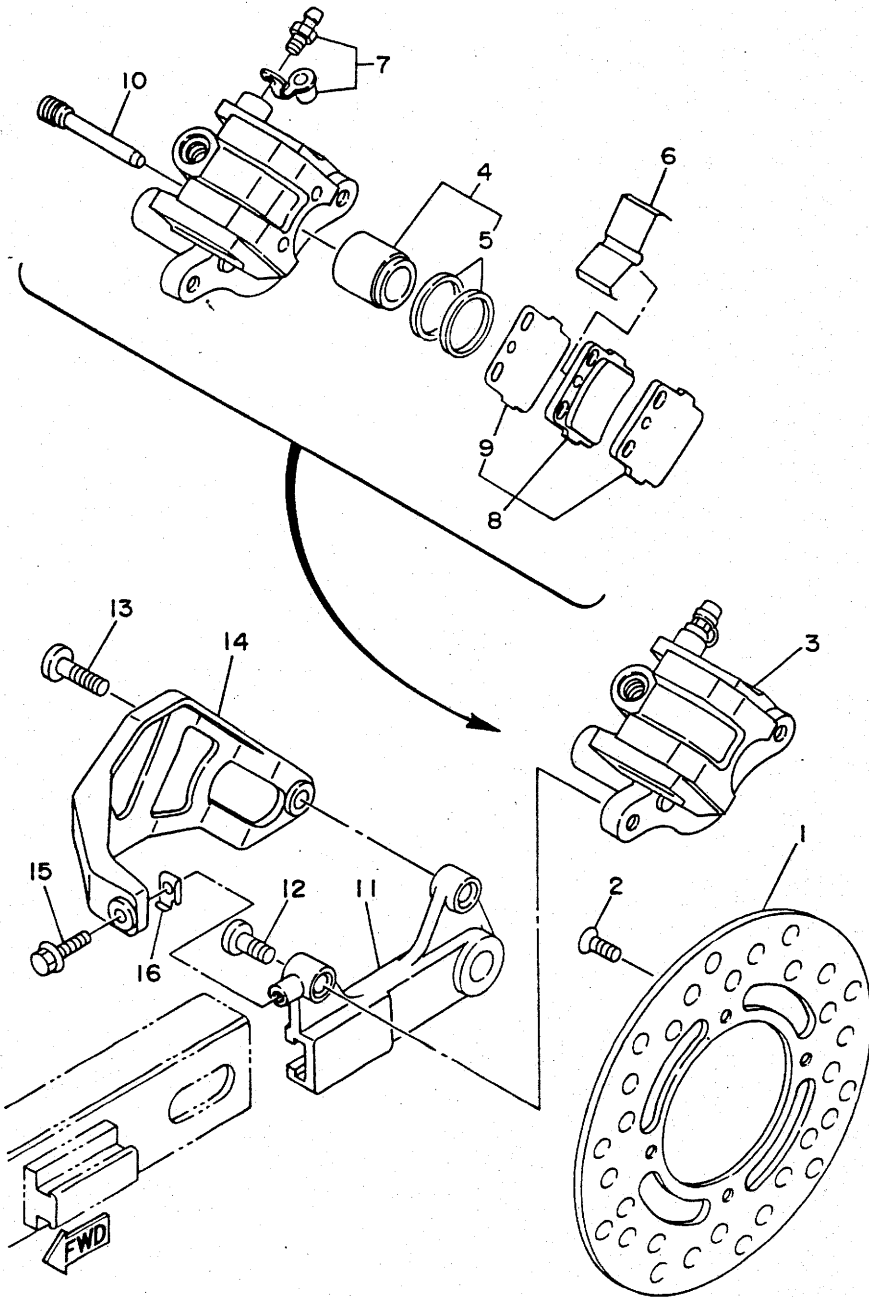

REF. NO.	PART NO.	DESCRIPTION	Q'TY	REMARKS
1	4ES-2582W-00	DISC, REAR BRAKE 2	1	
2	90149-06272	SCREW	4	
3	4ES-2580W-00	CALIPER ASSY, REAR 2	1	
4	4ES-W0057-00	.PISTON ASSY, CALIPER	1	
5	4ES-W0047-00	..CALIPER SEAL KIT	1	
6	1UY-25919-51	.SUPPORT, PAD	1	
7	36Y-W0048-00	.BREED SCREW KIT	1	
8	4ES-W0046-50	.BRAKE PAD KIT 2	1	
9	3GD-25827-00	..SHIM, CALIPER	1	
10	3GD-25933-00	.PIN, PAD	2	
11	4ES-25920-00	SUPT. BRKT. ASSY	1	
12	90110-08096	BOLT, HEXAGON SOCKET HEAD	1	
13	90109-08718	BOLT	1	
14	4ES-27491-00	PROTECTOR	1	
15	95023-06012	BOLT	1	
16	4ES-27114-00	STOPPER, MAIN STAND	1	

4ES1100-3270

D4

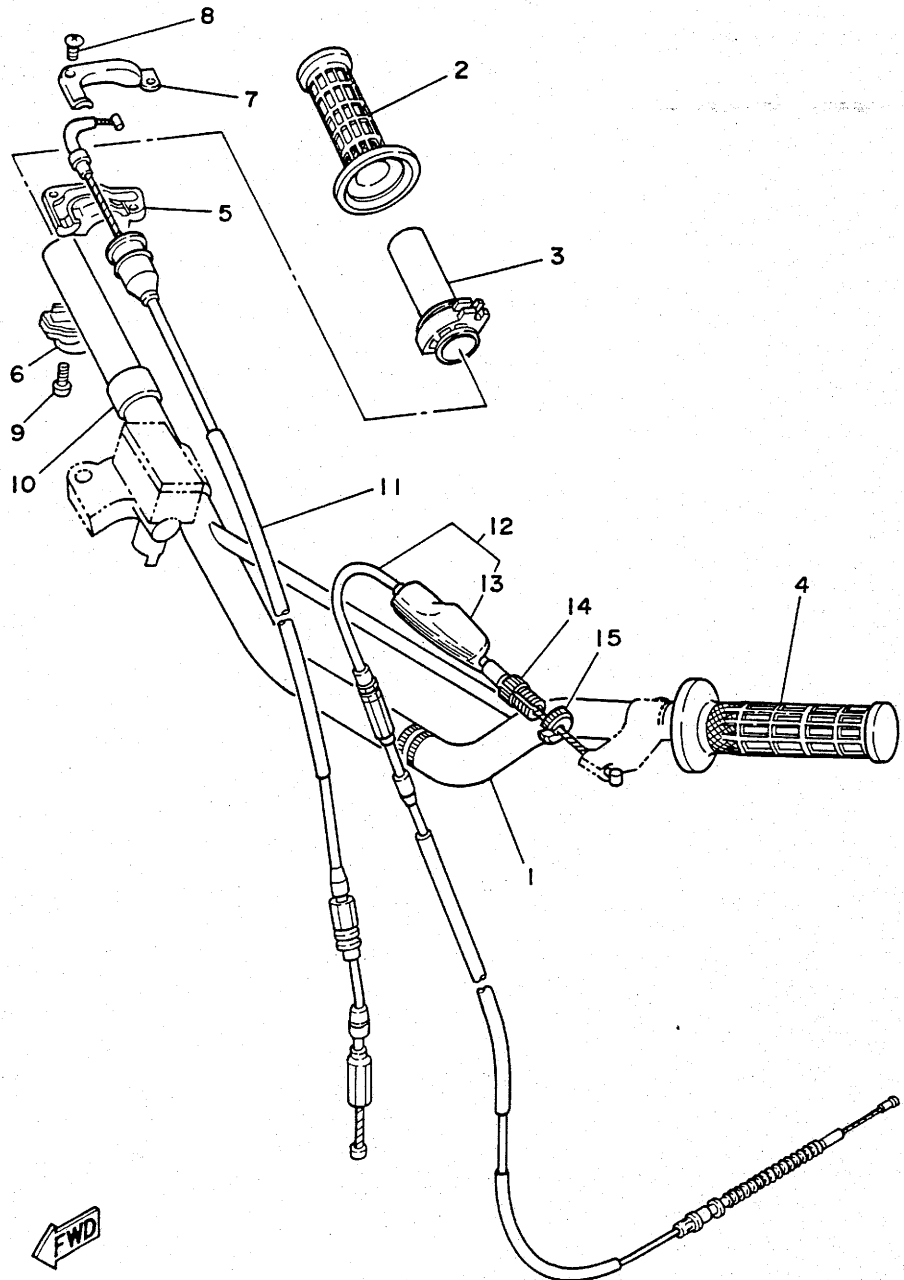

FIG. 28 STEERING HANDLE. CABLE

REF. NO.	PART NO.	DESCRIPTION	Q'TY	REMARKS
1	4ES-26111-00	HANDLEBAR	1	
2	1LX-26242-01	GRIP (RIGHT)	1	
3	22W-26243-00	TUBE, THROTTLE GUIDE	1	
4	1LX-26241-01	GRIP (LEFT)	1	
5	5X2-26281-00	CAP, GRIP UPPER	1	
6	322-26282-00	CAP, GRIP LOWER	1	
7	5X2-2628H-01	CAP, WIRE	1	
8	98706-04012	SCREW, FLAT HEAD	2	
9	98586-05016	SCREW, PAN HEAD	2	
10	90387-22647	COLLAR	1	
11	4ES-26311-00	CABLE, THROTTLE 1	1	
12	4ES-26335-00	CABLE, CLUTCH	1	
13	382-26372-01	.COVER, HANDLE LEVER 1	1	
14	90123-08013	BOLT	1	
15	90179-08148	NUT	1	

FWD

3MK4100-2270

D5

FIG. 29 FRONT MASTER CYLINDER

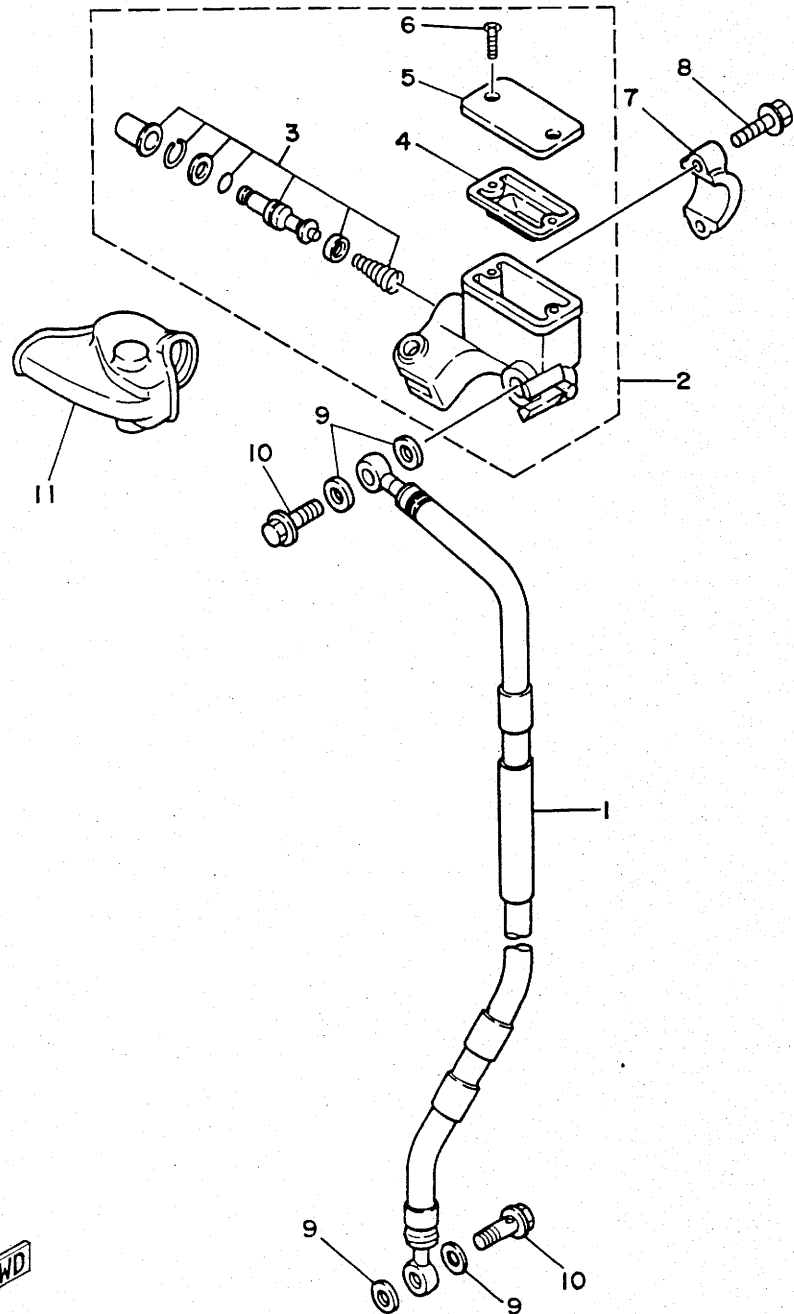

REF. NO.	PART NO.	DESCRIPTION	Q'TY	REMARKS
1	4ES-25872-00	HOSE, BRAKE 1	1	
2	2VN-25870-01	MASTER CYLINDER SUB ASSY	1	
3	56A-W0041-00	.CYLINDER KIT, MASTER	1	
4	56A-25854-00	.DIAPHRAGM, RESERVOIR	1	
5	2VN-25852-01	.CAP, RESERVOIR	1	
6	98706-04012	.SCREW, FLAT HEAD	2	
7	56A-25867-00	BRACKET, MASTER CYLINDER	1	
8	95026-06025	BOLT, FLANGE	2	
9	90201-10118	WASHER, PLATE	4	
10	90401-10034	BOLT, UNION	2	
11	56A-26372-01	COVER, HANDLE LEVER 1	1	

FWD

4ES1100-3290

D6

FIG. 30 STAND. FOOTREST

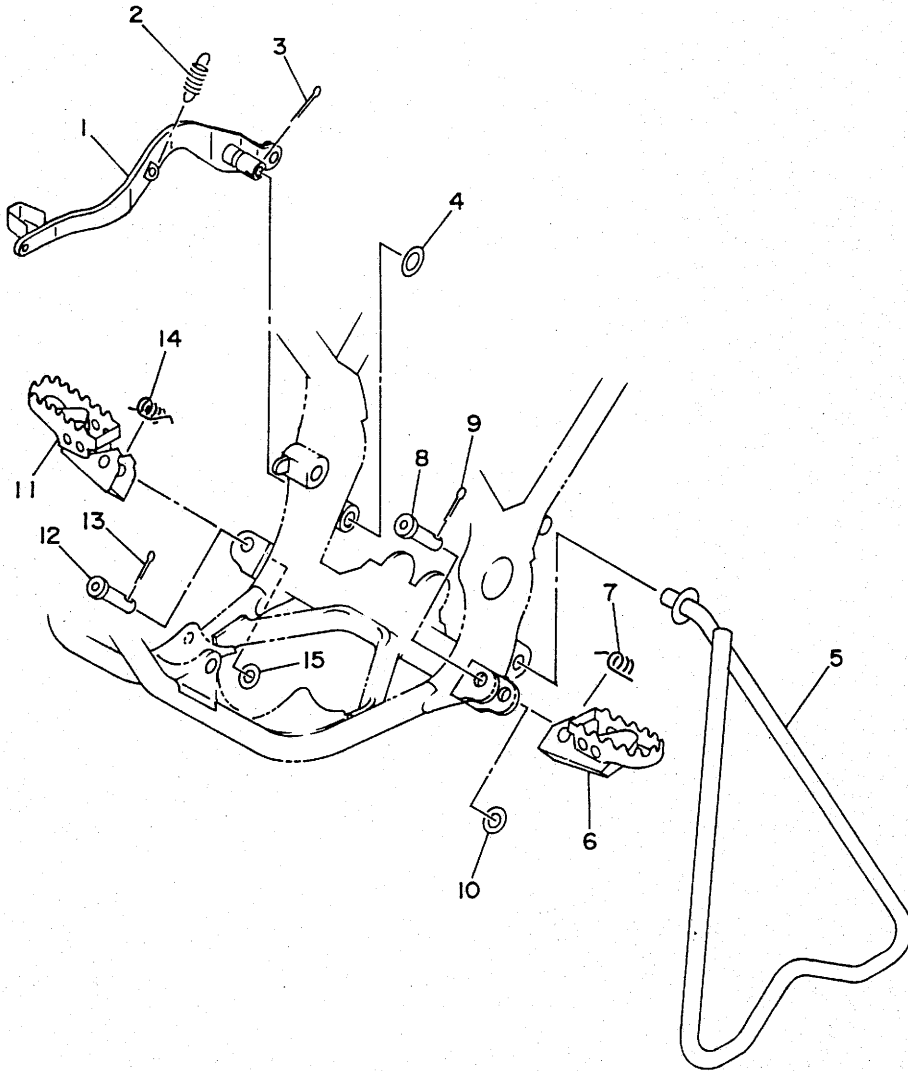

REF. NO.	PART NO.	DESCRIPTION	Q'TY	REMARKS
1	4ES-27211-00	PEDAL, BRAKE	1	
2	90506-15480	SPRING, TENSION	1	
3	91401-20030	PIN, COTTER	1	
4	90201-154E8	WASHER, PLATE	1	
5	4ES-27311-00	STAND, SIDE	1	
6	3SP-27411-00	FOOTREST 1	1	
7	90508-28777	SPRING, TORSION	1	
8	90240-10117	PIN, CLEVIS	1	
9	91401-25020	PIN, COTTER	1	
10	90201-10119	WASHER, PLATE	1	
11	3SP-27421-00	FOOTREST 2	1	
12	90240-10117	PIN, CLEVIS	1	
13	91401-25020	PIN, COTTER	1	
14	90508-28777	SPRING, TORSION	1	
15	90201-10119	WASHER, PLATE	1	



4ES1100-3300

D7

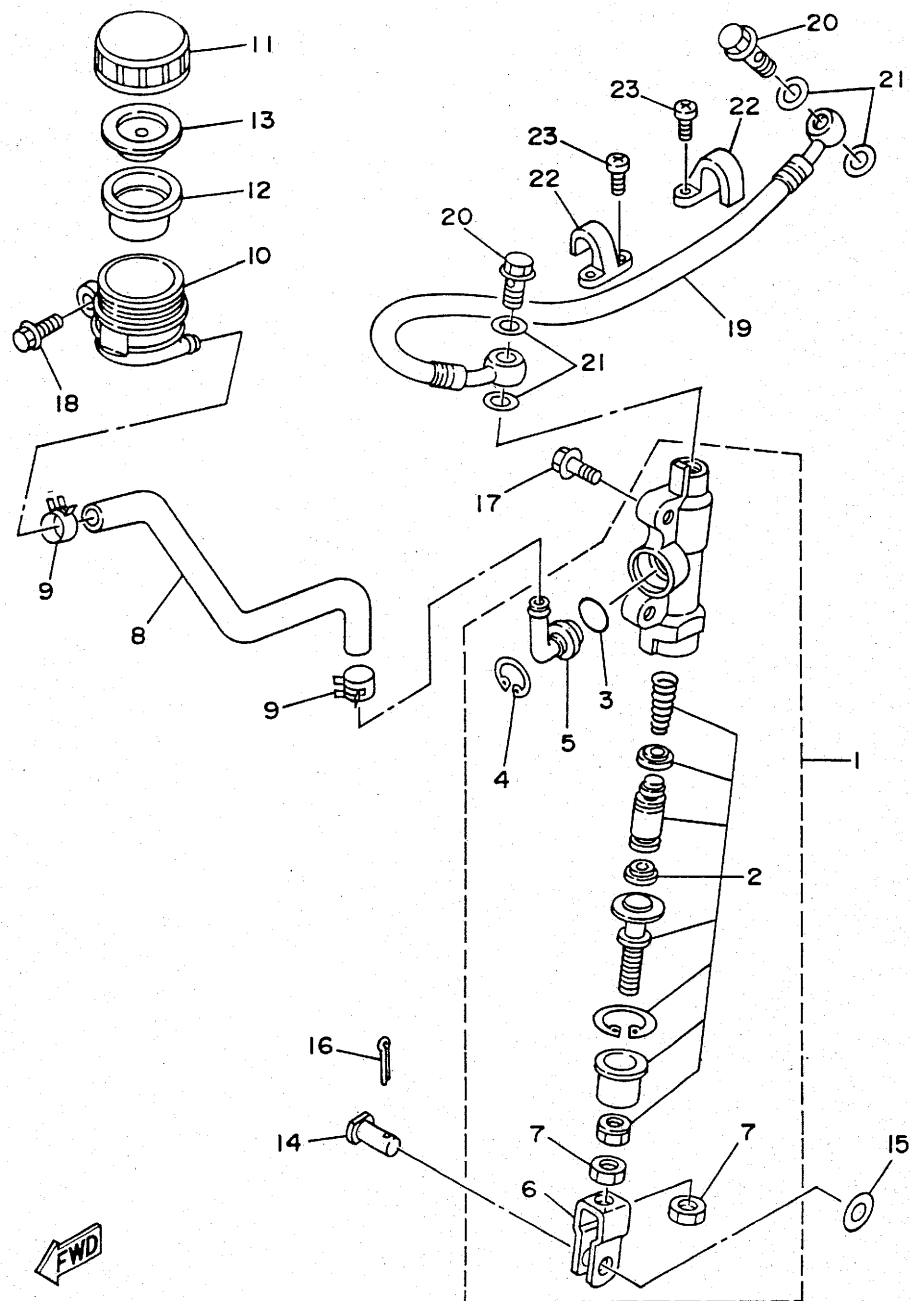

FIG. 31 REAR MASTER CYLINDER

REF. NO.	PART NO.	DESCRIPTION	Q'TY	REMARKS
1	4ES-2583V-00	RR. MASTER CYLINDER ASSY	1	
2	1FK-W0042-50	.CYLINDER KIT, MASTER	1	
3	93210-15620	.O-RING	1	
4	2VN-25866-00	.CIRCLIP	1	
5	2VN-2582A-50	.JOINT	1	
6	2YK-27222-00	.JOINT	1	
7	95333-08600	.NUT	2	
8	4ES-25895-00	HOSE, RESERVOIR	1	
9	90467-11044	CLIP	2	
10	4EW-25894-00	TANK, RESERVOIR	1	
11	3XP-25852-50	CAP, RESERVOIR	1	
12	2VN-25854-00	DIAPHRAGM, RESERVOIR	1	
13	2VN-25855-00	BUSH, DIAPHRAGM	1	
14	90240-08124	PIN, CLEVIS	1	
15	90201-08083	WASHER, PLATE	1	
16	91401-16020	PIN, COTTER	1	
17	95023-06016	BOLT	2	
18	95023-06012	BOLT	1	
19	4ES-25873-00	HOSE, BRAKE 2	1	
20	90401-10034	BOLT, UNION	2	
21	90201-10118	WASHER, PLATE	4	
22	2VM-25876-00	HOLDER, BRAKE HOSE 2	2	
23	97780-50110	SCREW, TAPPING	4	



4ES1100-3310

D8

FIG. 32 GENERATOR

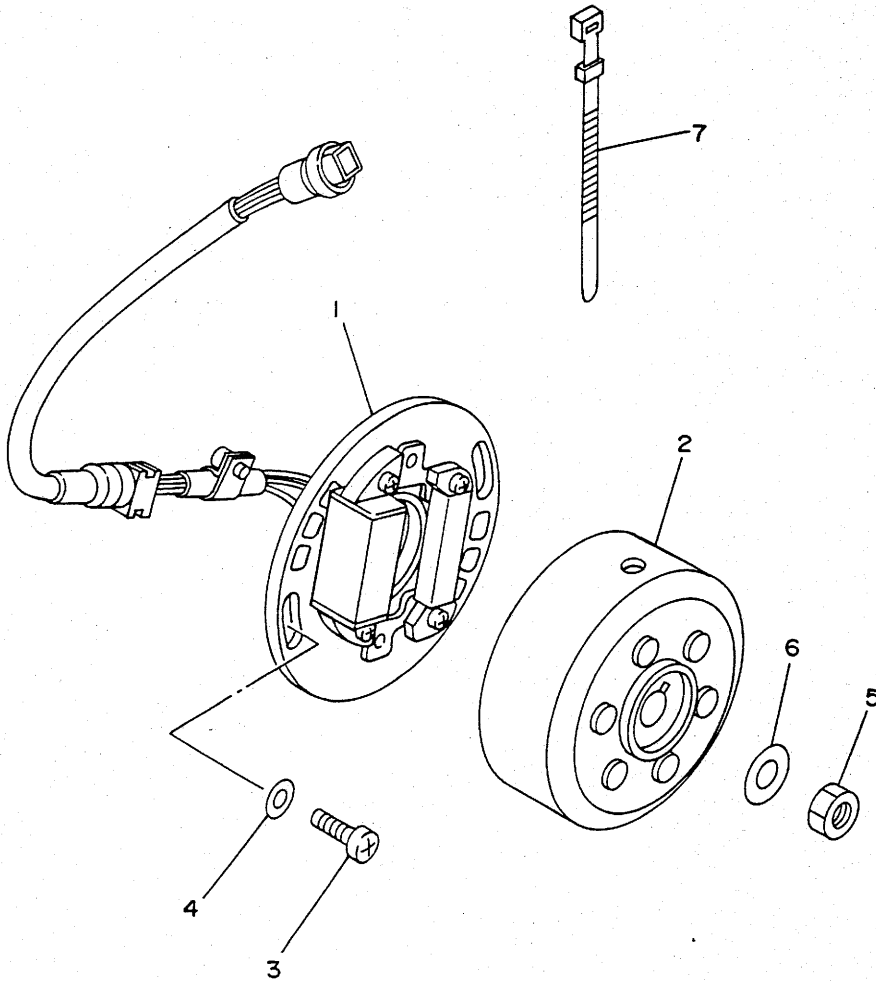

REF. NO.	PART NO.	DESCRIPTION	Q'TY	REMARKS
1	4ES-85510-00	STATOR ASSY	1	
2	4ES-85550-00	ROTOR ASSY	1	
3	98502-06016	SCREW, PAN HEAD	2	
4	92901-06600	WASHER, PLATE	2	
5	95311-10600	NUT	1	
6	90201-10774	WASHER, PLATE	1	
7	437-83936-01	BAND, SWITCH CORD	3	



4ES1100-3320

D9

FIG. 33 HANDLE SWITCH. LEVER

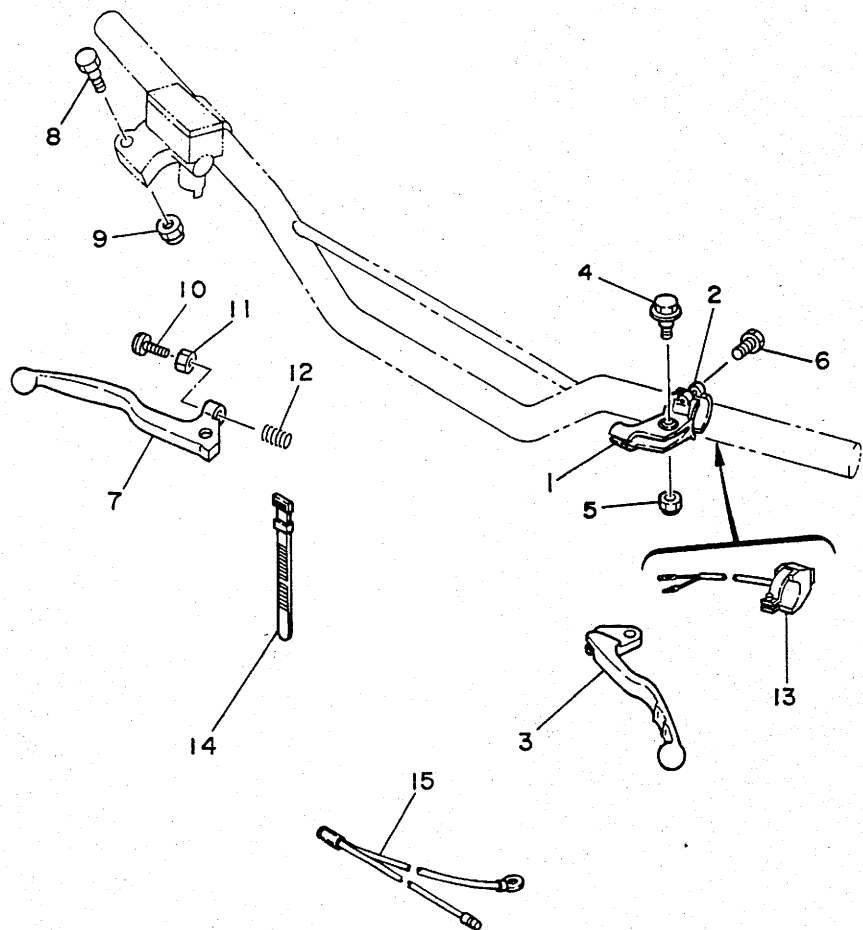

REF. NO.	PART NO.	DESCRIPTION	Q'TY	REMARKS
1	38V-82911-00	HOLDER, LEVER 1	1	
2	38V-82913-00	HOLDER, LEVER LOWER 1	1	
3	23X-83912-00	LEVER 1	1	
4	90109-06799	BOLT	1	
5	95616-06100	NUT, U	1	
6	97006-05016	BOLT	2	
7	55Y-83922-00	LEVER 2	1	
8	90109-06577	BOLT	1	
9	95616-06100	NUT, U	1	
10	90143-06024	SCREW, HEXAGON	1	
11	90170-06010	NUT	1	
12	90501-06162	SPRING, COMPRESSION	1	
13	23X-83976-00	SWITCH, HANDLE 1	1	
14	437-83936-01	BAND, SWITCH CORD	2	
15	5X1-82519-01	WIRE, EARTH LEAD	1	



4ES1100-3330

D10

FIG. 34 ELECTRICAL 1

REF. NO.	PART NO.	DESCRIPTION	Q'TY	REMARKS
1	4ES-85540-00	C.D.I. UNIT ASSY	1	
2	2A7-85546-00	BAND	1	
3	437-83936-11	BAND, SWITCH CORD	1	
4	436-82310-40	IGNITION COIL ASSY	1	
5	98580-06020	SCREW, PAN HEAD	2	
6	92995-06100	WASHER	2	
7	81E-82370-20	PLUG CAP ASSY	1	

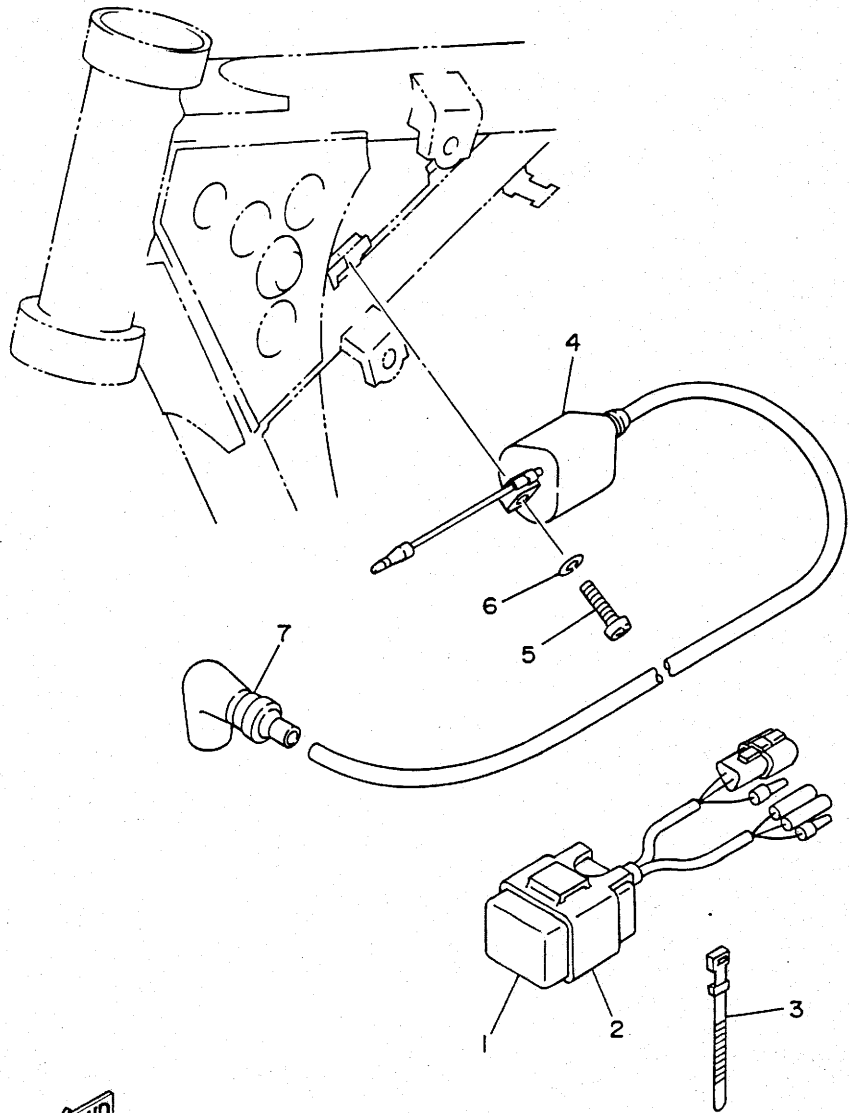

4ES1100-3340

D11

FIG. 35 ALTERNATE (CHASSIS)

REF. NO.	PART NO.	DESCRIPTION	Q'TY	REMARKS
1	4ES-22212-10	SPRING	1	AP (SOFT)
	4ES-22212-20	SPRING	1	AP (HARD)
2	4ES-23141-10	SPRING, FRONT FORK	2	AP (SOFT)
	4ES-23141-20	SPRING, FRONT FORK	2	AP (HARD)

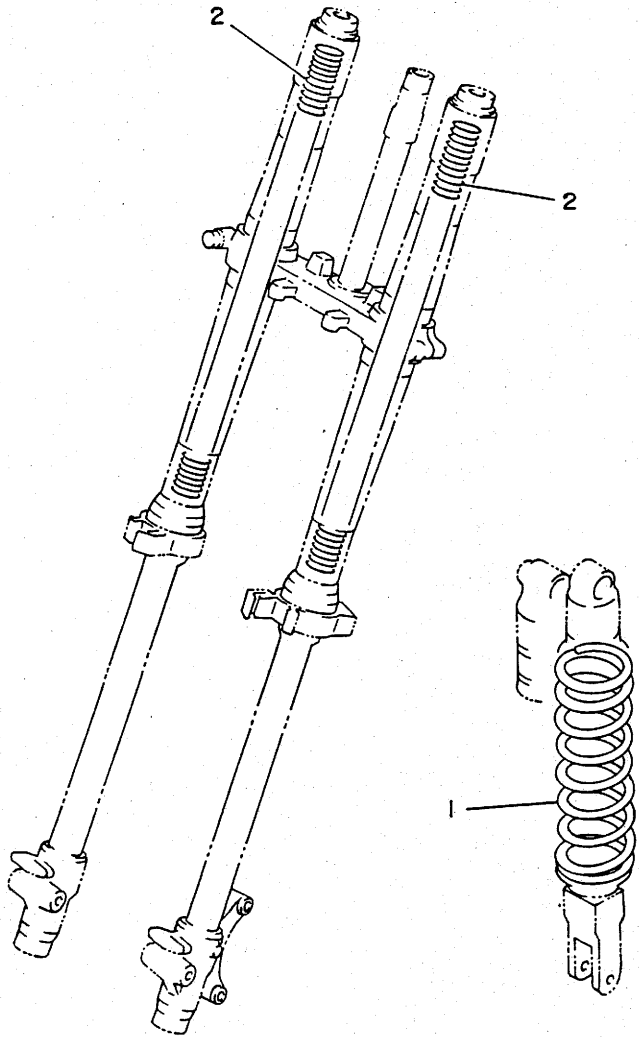

4ES1100-3350

D12

FIG. 36 REPAIR KIT

REF. NO.	PART NO.	DESCRIPTION	Q'TY	REMARKS
1	4ES-11630-00	PISTON ASSY (STD)	1	
2	4ES-11631-00-B0	.PISTON (STD)	1	
3	43K-11611-00	.RING, PISTON	1	
4	4ES-11633-00	.PIN, PISTON	1	
5	93450-16115	.CIRCLIP	2	
6	4ES-11650-00	CONNECTING ROD ASSY	1	
7	4ES-11651-00	.ROD, CONNECTING	1	
8	93310-420D8	.BEARING, CYLINDRICAL	1	
9	2RA-11681-00	.PIN, CRANK 1	1	
10	90209-20159	.WASHER	2	
11	93310-214F8	.BEARING, CYLINDRICAL	1	KOYO

D13